

**VERY LOW DROP  
VOLTAGE REGULATORS WITH INHIBIT**

PRELIMINARY DATA

- VERY LOW DROPOUT VOLTAGE (0.4V)
- VERY LOW QUIESCENT CURRENT  
(TYP. 50  $\mu$ A IN OFF MODE, 600 $\mu$ A IN ON MODE)
- OUTPUT CURRENT UP TO 250 mA
- LOGIC-CONTROLLED ELECTRONIC SHUTDOWN
- OUTPUT VOLTAGES OF 1.25; 1.5; 2.5; 2.7; 3; 3.3; 3.5; 4; 4.5; 4.7; 5; 5.2; 5.5; 6; 8; 12V
- INTERNAL CURRENT AND THERMAL LIMIT
- ONLY 2.2 $\mu$ F FOR STABILITY
- AVAILABLE IN  $\pm$  1% (AB) OR 2% (C) SELECTION AT 25  $^{\circ}$ C
- SUPPLY VOLTAGE REJECTION: 70db TYP. FOR 5V VERSION
- TEMPERATURE RANGE: -40 TO 125  $^{\circ}$ C

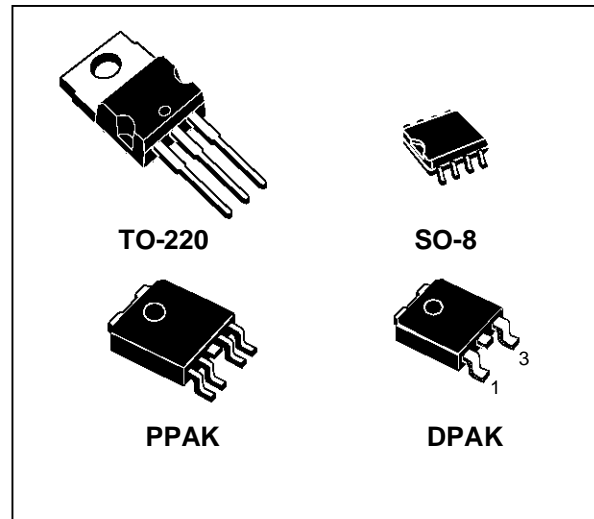

**DESCRIPTION**

The L4931 series are very Low Drop regulators available in TO-220, SO-8, DPAK and PPAK packages and in a wide range of output voltages. The very Low Drop voltage (0.4V) and the very low quiescent current make them particularly suitable for Low Noise, Low Power applications and specially in battery powered systems.

In PPAK and SO-8 packages a Shutdown Logic Control function is available TTL compatible. This means that when the device is used as a local regulator, it is possible to put a part of the board in standby, decreasing the total power consumption. It requires only a 2.2  $\mu$ F capacitor for stability allowing space and cost saving.

**SCHEMATIC DIAGRAM**

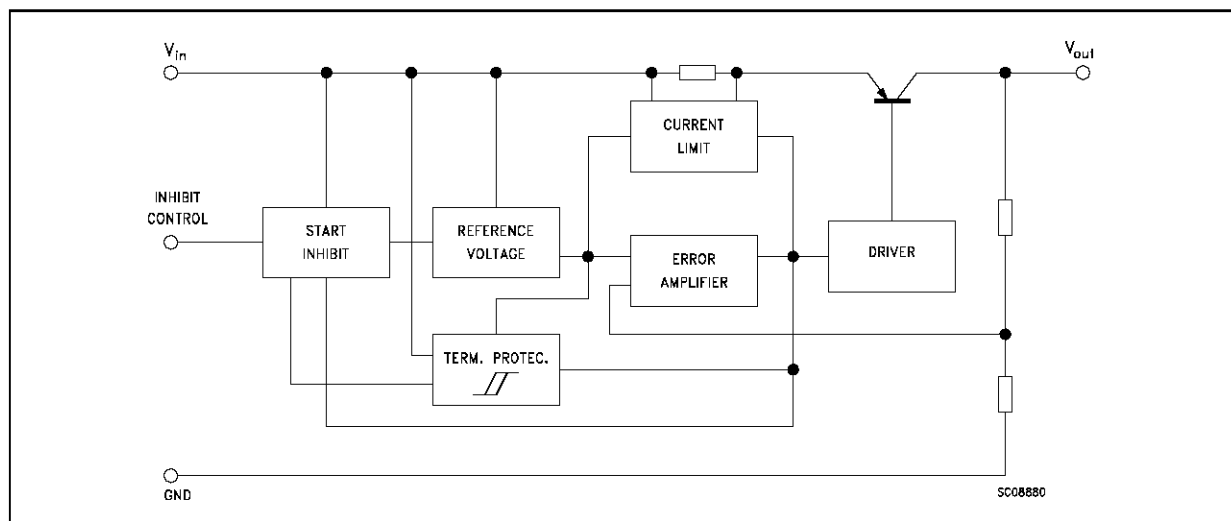

# L4931 SERIES

## ABSOLUTE MAXIMUM RATINGS

Symbol	Parameter	Value	Unit
$V_i$	DC Input Voltage	20	V
$I_o$	Output Current	Internally limited	
$P_{tot}$	Power Dissipation	Internally limited	
$T_{stg}$	Storage Temperature Range	- 40 to 150	°C
$T_{op}$	Operating Junction Temperature Range	- 40 to 125	°C

## THERMAL DATA

Symbol	Parameter	TO-220	SO-8	DPAK	PPAK	Unit
$R_{thj-case}$	Thermal Resistance Junction-case	3	20	8	8	°C/W
$R_{thj-amb}$	Thermal Resistance Junction-ambient	50		100	100	°C/W

## CONNECTION DIAGRAM (top view)

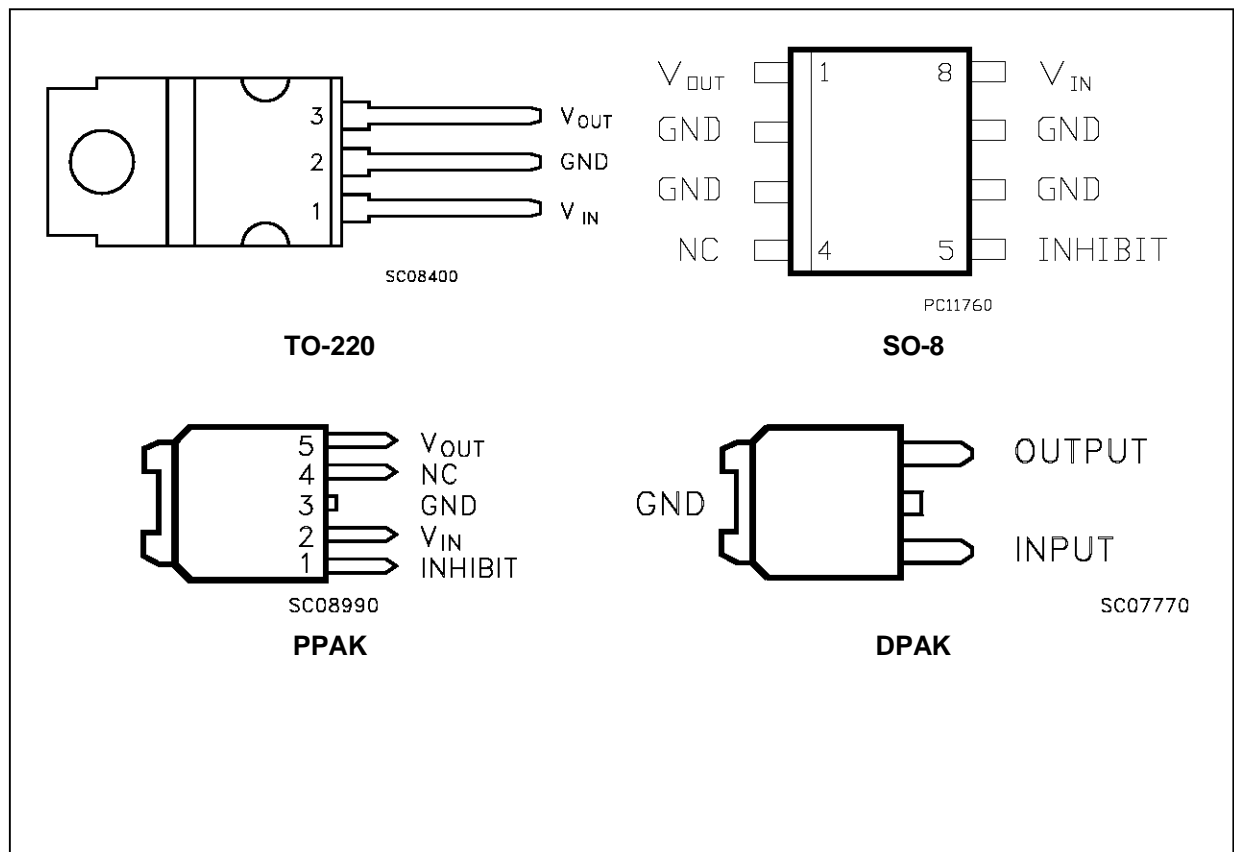

ORDERING NUMBERS

TO-220	SO-8	PPAK	DPAK	Output Voltage
L4931CV12 (*)	L4931CD12 (*)	L4931CPT12 (*)	L4931CDT12 (*)	1.25 V
L4931ABV12 (*)	L4931ABD12 (*)	L4931ABPT12 (*)	L4931ABDT12 (*)	1.25 V
L4931CV15 (*)	L4931CD15 (*)	L4931CPT15 (*)	L4931CDT15 (*)	1.5 V
L4931ABV15 (*)	L4931ABD15 (*)	L4931ABPT15 (*)	L4931ABDT15 (*)	1.5 V
L4931CV25 (*)	L4931CD25 (*)	L4931CPT25 (*)	L4931CDT25 (*)	2.5 V
L4931ABV25 (*)	L4931ABD25 (*)	L4931ABPT25 (*)	L4931ABDT25 (*)	2.5 V
L4931CV27	L4931CD27	L4931CPT27	L4931CDT27	2.7 V
L4931ABV27	L4931ABD27	L4931ABPT27	L4931ABDT27	2.7 V
L4931CV30	L4931CD30	L4931CPT30	L4931CDT30	3 V
L4931ABV30	L4931ABD30	L4931ABPT30	L4931ABDT30	3 V
L4931CV33	L4931CD33	L4931CPT33	L4931CDT33	3.3 V
L4931AB33	L4931AB33	L4931AB33	L4931AB33	3.3 V
L4931CV35	L4931CD35	L4931CPT35	L4931CDT35	3.5 V
L4931ABV35	L4931ABD35	L4931ABPT35	L4931ABDT35	3.5 V
L4931CV40	L4931CD40	L4931CPT40	L4931CDT40	4 V
L4931ABV40	L4931ABD40	L4931ABPT40	L4931ABDT40	4 V
L4931CV45 (*)	L4931CD45 (*)	L4931CPT45 (*)	L4931CDT45 (*)	4.5 V
L4931ABV45 (*)	L4931ABD45 (*)	L4931ABPT45 (*)	L4931ABDT45 (*)	4.5 V
L4931CV47	L4931CD47	L4931CPT47	L4931CDT47	4.75 V
L4931ABV47	L4931ABD47	L4931ABPT47	L4931ABDT47	4.75 V
L4931CV50	L4931CD50	L4931CPT50	L4931CDT50	5 V
L4931ABV50	L4931ABD50	L4931ABPT50	L4931ABDT50	5 V
L4931CV52 (*)	L4931CD52 (*)	L4931CPT52 (*)	L4931CDT52 (*)	5.2 V
L4931ABV52 (*)	L4931ABD52 (*)	L4931ABPT52 (*)	L4931ABDT52 (*)	5.2 V
L4931CV55 (*)	L4931CD55 (*)	L4931CPT55 (*)	L4931CDT55 (*)	5.5 V
L4931ABV55 (*)	L4931ABD55 (*)	L4931ABPT55 (*)	L4931ABDT55 (*)	5.5 V
L4931CV60	L4931CD60	L4931CPT60	L4931CDT60	6 V
L4931ABV60	L4931ABD60	L4931ABPT60	L4931ABDT60	6 V
L4931CV80	L4931CD80	L4931CPT80	L4931CDT80	8 V
L4931ABV80	L4931ABD80	L4931ABPT80	L4931ABDT80	8 V
L4931CV120	L4931CD120	L4931CPT120	L4931CDT120	12 V
L4931ABV120	L4931ABD120	L4931ABPT120	L4931ABDT120	12 V

(\*) Available on request

TEST CIRCUITS

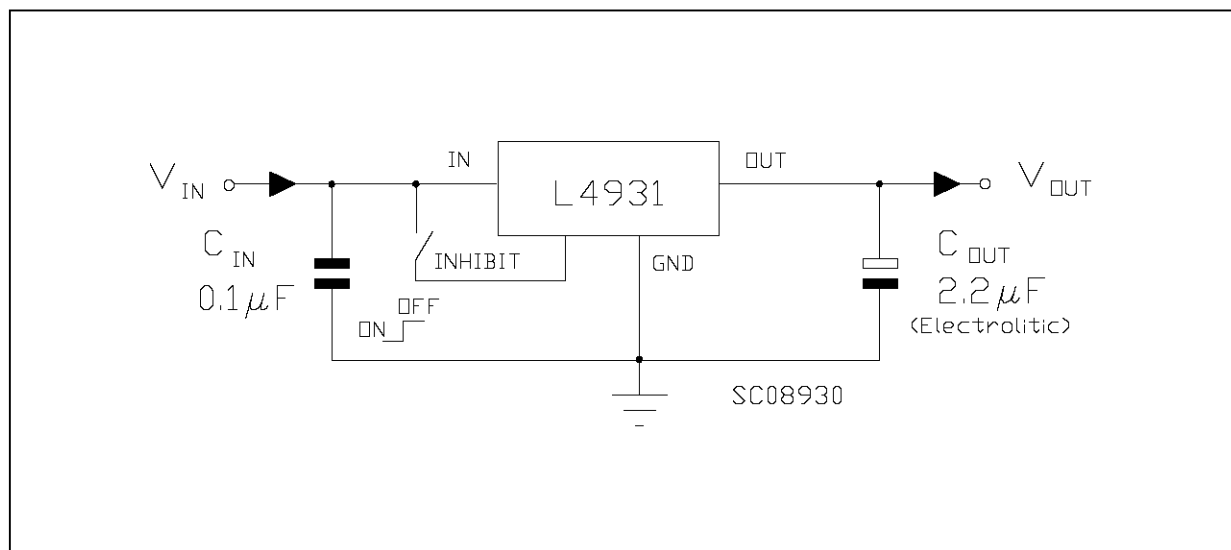

## L4931 SERIES

**ELECTRICAL CHARACTERISTICS FOR L4931ABxx12** (refer to the test circuits,  $T_j = 25\text{ }^\circ\text{C}$ ,  $C_i = 0.1\text{ }\mu\text{F}$ ,  $C_o = 2.2\text{ }\mu\text{F}$  unless otherwise specified)

Symbol	Parameter	Test Conditions	Min.	Typ.	Max.	Unit
$V_o$	Output Voltage	$I_o = 5\text{ mA}$ , $V_i = 3.3\text{ V}$ $I_o = 5\text{ mA}$ , $V_i = 3.3\text{ V}$ $-25 < T_a < 85\text{ }^\circ\text{C}$	1.238 1.225	1.25	1.263 1.275	V V
$V_i$	Operating Input Voltage	$I_o = 250\text{ mA}$	2.5		20	V
$I_{out}$	Output Current Limit			300		mA
$\Delta V_o$	Line Regulation	$V_i = 2.5\text{ to }20\text{ V}$ , $I_o = 0.5\text{ mA}$		3	15	mV
$\Delta V_o(*)$	Load Regulation	$V_i = 2.7\text{ V}$ $I_o = 0.5\text{ to }250\text{ mA}$		3	15	mV
$I_d$	Quiescent Current	ON MODE $V_i = 2.7\text{ to }20\text{ V}$ $I_o = 0\text{ mA}$ $V_i = 2.7\text{ to }20\text{ V}$ $I_o = 250\text{ mA}$		0.6 4	1 6	mA mA
		OFF MODE $V_i = 6\text{ V}$		50	100	$\mu\text{A}$
SVR	Supply Voltage Rejection	$I_o = 5\text{ mA}$ $V_i = 3.7\text{ V} \pm 1\text{ V}$ $f = 120\text{ Hz}$ $f = 1\text{ KHz}$ $f = 10\text{ KHz}$		80 77 55		dB dB dB
eN	Output Noise Voltage	$B = 10\text{ Hz to }100\text{ KHz}$		50		$\mu\text{V}$
$V_d(*)$	Dropout Voltage	$I_o = 250\text{ mA}$		1.25		V
$V_{il}$	Control Input Logic Low	$-40 < T_a < 125\text{ }^\circ\text{C}$			0.8	V
$V_{ih}$	Control Input Logic High	$-40 < T_a < 125\text{ }^\circ\text{C}$	2			V
$I_i$	Control Input Current	$V_i = 6\text{ V}$ , $V_c = 6\text{ V}$		10		$\mu\text{A}$
$C_o$	Output Bypass Capacitance	$\text{ESR} = 0.1\text{ to }10\text{ }\Omega$ $I_o = 0\text{ to }250\text{ mA}$	2	10		$\mu\text{F}$

**ELECTRICAL CHARACTERISTICS FOR L4931Cxx12** (refer to the test circuits,  $T_j = 25\text{ }^\circ\text{C}$ ,  $C_i = 0.1\text{ }\mu\text{F}$ ,  $C_o = 2.2\text{ }\mu\text{F}$  unless otherwise specified)

Symbol	Parameter	Test Conditions	Min.	Typ.	Max.	Unit
$V_o$	Output Voltage	$I_o = 5\text{ mA}$ , $V_i = 3.3\text{ V}$ $I_o = 5\text{ mA}$ , $V_i = 3.3\text{ V}$ $-25 < T_a < 85\text{ }^\circ\text{C}$	1.225 1.2	1.25	1.275 1.3	V V
$V_i$	Operating Input Voltage	$I_o = 250\text{ mA}$	2.5		20	V
$I_{out}$	Output Current Limit			300		mA
$\Delta V_o$	Line Regulation	$V_i = 2.5\text{ to }20\text{ V}$ , $I_o = 0.5\text{ mA}$		3	18	mV
$\Delta V_o(*)$	Load Regulation	$V_i = 2.7\text{ V}$ $I_o = 0.5\text{ to }250\text{ mA}$		3	18	mV
$I_d$	Quiescent Current	ON MODE $V_i = 2.7\text{ to }20\text{ V}$ $I_o = 0\text{ mA}$ $V_i = 2.7\text{ to }20\text{ V}$ $I_o = 250\text{ mA}$		0.6 4	1 6	mA mA
		OFF MODE $V_i = 6\text{ V}$		50	100	$\mu\text{A}$
SVR	Supply Voltage Rejection	$I_o = 5\text{ mA}$ $V_i = 3.7\text{ V} \pm 1\text{ V}$ $f = 120\text{ Hz}$ $f = 1\text{ KHz}$ $f = 10\text{ KHz}$		80 77 55		dB dB dB
eN	Output Noise Voltage	$B = 10\text{ Hz to }100\text{ KHz}$		50		$\mu\text{V}$
$V_d(*)$	Dropout Voltage	$I_o = 250\text{ mA}$		1.25		V
$V_{il}$	Control Input Logic Low	$-40 < T_a < 125\text{ }^\circ\text{C}$			0.8	V
$V_{ih}$	Control Input Logic High	$-40 < T_a < 125\text{ }^\circ\text{C}$	2			V
$I_i$	Control Input Current	$V_i = 6\text{ V}$ , $V_c = 6\text{ V}$		10		$\mu\text{A}$
$C_o$	Output Bypass Capacitance	$\text{ESR} = 0.1\text{ to }10\text{ }\Omega$ $I_o = 0\text{ to }250\text{ mA}$	2	10		$\mu\text{F}$

(\*) For SO-8 package the maximum limit of load regulation and dropout is increased by 20mV

**ELECTRICAL CHARACTERISTICS FOR L4931ABxx15** (refer to the test circuits,  $T_j = 25\text{ }^\circ\text{C}$ ,  $C_i = 0.1\text{ }\mu\text{F}$ ,  $C_o = 2.2\text{ }\mu\text{F}$  unless otherwise specified)

Symbol	Parameter	Test Conditions	Min.	Typ.	Max.	Unit
$V_o$	Output Voltage	$I_o = 5\text{ mA}$ , $V_i = 3.5\text{ V}$ $I_o = 5\text{ mA}$ , $V_i = 3.5\text{ V}$ $-25 < T_a < 85\text{ }^\circ\text{C}$	1.485 1.47	1.5	1.515 1.53	V V
$V_i$	Operating Input Voltage	$I_o = 250\text{ mA}$	2.5		20	V
$I_{out}$	Output Current Limit			300		mA
$\Delta V_o$	Line Regulation	$V_i = 2.5\text{ to }20\text{ V}$ , $I_o = 0.5\text{ mA}$		3	15	mV
$\Delta V_o(*)$	Load Regulation	$V_i = 2.7\text{ V}$ $I_o = 0.5\text{ to }250\text{ mA}$		3	15	mV
$I_d$	Quiescent Current	ON MODE $V_i = 2.7\text{ to }20\text{ V}$ $I_o = 0\text{ mA}$ $V_i = 2.7\text{ to }20\text{ V}$ $I_o = 250\text{ mA}$		0.6 4	1 6	mA mA
		OFF MODE $V_i = 6\text{ V}$		50	100	$\mu\text{A}$
SVR	Supply Voltage Rejection	$I_o = 5\text{ mA}$ $V_i = 3.7\text{ V} \pm 1\text{ V}$ $f = 120\text{ Hz}$ $f = 1\text{ KHz}$ $f = 10\text{ KHz}$		79 76 55		dB dB dB
eN	Output Noise Voltage	$B = 10\text{ Hz to }100\text{ KHz}$		50		$\mu\text{V}$
$V_d(*)$	Dropout Voltage	$I_o = 250\text{ mA}$		1		V
$V_{il}$	Control Input Logic Low	$-40 < T_a < 125\text{ }^\circ\text{C}$			0.8	V
$V_{ih}$	Control Input Logic High	$-40 < T_a < 125\text{ }^\circ\text{C}$	2			V
$I_i$	Control Input Current	$V_i = 6\text{ V}$ , $V_c = 6\text{ V}$		10		$\mu\text{A}$
$C_o$	Output Bypass Capacitance	$\text{ESR} = 0.1\text{ to }10\text{ }\Omega$ $I_o = 0\text{ to }250\text{ mA}$	2	10		$\mu\text{F}$

**ELECTRICAL CHARACTERISTICS FOR L4931Cxx15** (refer to the test circuits,  $T_j = 25\text{ }^\circ\text{C}$ ,  $C_i = 0.1\text{ }\mu\text{F}$ ,  $C_o = 2.2\text{ }\mu\text{F}$  unless otherwise specified)

Symbol	Parameter	Test Conditions	Min.	Typ.	Max.	Unit
$V_o$	Output Voltage	$I_o = 5\text{ mA}$ , $V_i = 3.5\text{ V}$ $I_o = 5\text{ mA}$ , $V_i = 3.5\text{ V}$ $-25 < T_a < 85\text{ }^\circ\text{C}$	1.47 1.44	1.5	1.53 1.56	V V
$V_i$	Operating Input Voltage	$I_o = 250\text{ mA}$	2.5		20	V
$I_{out}$	Output Current Limit			300		mA
$\Delta V_o$	Line Regulation	$V_i = 2.5\text{ to }20\text{ V}$ , $I_o = 0.5\text{ mA}$		3	18	mV
$\Delta V_o(*)$	Load Regulation	$V_i = 2.7\text{ V}$ $I_o = 0.5\text{ to }250\text{ mA}$		3	18	mV
$I_d$	Quiescent Current	ON MODE $V_i = 2.7\text{ to }20\text{ V}$ $I_o = 0\text{ mA}$ $V_i = 2.7\text{ to }20\text{ V}$ $I_o = 250\text{ mA}$		0.6 4	1 6	mA mA
		OFF MODE $V_i = 6\text{ V}$		50	100	$\mu\text{A}$
SVR	Supply Voltage Rejection	$I_o = 5\text{ mA}$ $V_i = 3.7\text{ V} \pm 1\text{ V}$ $f = 120\text{ Hz}$ $f = 1\text{ KHz}$ $f = 10\text{ KHz}$		79 76 55		dB dB dB
eN	Output Noise Voltage	$B = 10\text{ Hz to }100\text{ KHz}$		50		$\mu\text{V}$
$V_d(*)$	Dropout Voltage	$I_o = 250\text{ mA}$		1		V
$V_{il}$	Control Input Logic Low	$-40 < T_a < 125\text{ }^\circ\text{C}$			0.8	V
$V_{ih}$	Control Input Logic High	$-40 < T_a < 125\text{ }^\circ\text{C}$	2			V
$I_i$	Control Input Current	$V_i = 6\text{ V}$ , $V_c = 6\text{ V}$		10		$\mu\text{A}$
$C_o$	Output Bypass Capacitance	$\text{ESR} = 0.1\text{ to }10\text{ }\Omega$ $I_o = 0\text{ to }250\text{ mA}$	2	10		$\mu\text{F}$

(\*) For SO-8 package the maximum limit of load regulation and dropout is increased by 20mV

## L4931 SERIES

**ELECTRICAL CHARACTERISTICS FOR L4931ABxx25** (refer to the test circuits,  $T_j = 25\text{ }^\circ\text{C}$ ,  $C_i = 0.1\text{ }\mu\text{F}$ ,  $C_o = 2.2\text{ }\mu\text{F}$  unless otherwise specified)

Symbol	Parameter	Test Conditions	Min.	Typ.	Max.	Unit
$V_o$	Output Voltage	$I_o = 5\text{ mA}$ , $V_i = 4.5\text{ V}$ $I_o = 5\text{ mA}$ , $V_i = 4.5\text{ V}$ $-25 < T_a < 85\text{ }^\circ\text{C}$	2.475 2.45	2.5	2.525 2.55	V V
$V_i$	Operating Input Voltage	$I_o = 250\text{ mA}$			20	V
$I_{out}$	Output Current Limit			300		mA
$\Delta V_o$	Line Regulation	$V_i = 3.2\text{ to }20\text{ V}$ , $I_o = 0.5\text{ mA}$		3	15	mV
$\Delta V_o(*)$	Load Regulation	$V_i = 3.4\text{ V}$ $I_o = 0.5\text{ to }250\text{ mA}$		3	15	mV
$I_d$	Quiescent Current	ON MODE $V_i = 3.4\text{ to }20\text{ V}$ $I_o = 0\text{ mA}$ $V_i = 3.4\text{ to }20\text{ V}$ $I_o = 250\text{ mA}$		0.6 4	1 6	mA mA
		OFF MODE $V_i = 6\text{ V}$		50	100	$\mu\text{A}$
SVR	Supply Voltage Rejection	$I_o = 5\text{ mA}$ $V_i = 4.4\text{ V} \pm 1\text{ V}$ $f = 120\text{ Hz}$ $f = 1\text{ KHz}$ $f = 10\text{ KHz}$		75 72 55		dB dB dB
eN	Output Noise Voltage	$B = 10\text{ Hz to }100\text{ KHz}$		50		$\mu\text{V}$
$V_d(*)$	Dropout Voltage	$I_o = 250\text{ mA}$ $I_o = 250\text{ mA}$ $-40 < T_j < 125\text{ }^\circ\text{C}$		0.4	0.6 0.8	V V
$V_{il}$	Control Input Logic Low	$-40 < T_a < 125\text{ }^\circ\text{C}$			0.8	V
$V_{ih}$	Control Input Logic High	$-40 < T_a < 125\text{ }^\circ\text{C}$	2			V
$I_i$	Control Input Current	$V_i = 6\text{ V}$ , $V_c = 6\text{ V}$		10		$\mu\text{A}$
$C_o$	Output Bypass Capacitance	$\text{ESR} = 0.1\text{ to }10\text{ }\Omega$ $I_o = 0\text{ to }250\text{ mA}$	2	10		$\mu\text{F}$

**ELECTRICAL CHARACTERISTICS FOR L4931Cxx25** (refer to the test circuits,  $T_j = 25\text{ }^\circ\text{C}$ ,  $C_i = 0.1\text{ }\mu\text{F}$ ,  $C_o = 2.2\text{ }\mu\text{F}$  unless otherwise specified)

Symbol	Parameter	Test Conditions	Min.	Typ.	Max.	Unit
$V_o$	Output Voltage	$I_o = 5\text{ mA}$ , $V_i = 4.5\text{ V}$ $I_o = 5\text{ mA}$ , $V_i = 4.5\text{ V}$ $-25 < T_a < 85\text{ }^\circ\text{C}$	2.45 2.4	2.5	2.55 2.6	V V
$V_i$	Operating Input Voltage	$I_o = 250\text{ mA}$			20	V
$I_{out}$	Output Current Limit			300		mA
$\Delta V_o$	Line Regulation	$V_i = 3.3\text{ to }20\text{ V}$ , $I_o = 0.5\text{ mA}$		3	18	mV
$\Delta V_o(*)$	Load Regulation	$V_i = 3.5\text{ V}$ $I_o = 0.5\text{ to }250\text{ mA}$		3	18	mV
$I_d$	Quiescent Current	ON MODE $V_i = 3.5\text{ to }20\text{ V}$ $I_o = 0\text{ mA}$ $V_i = 3.5\text{ to }20\text{ V}$ $I_o = 250\text{ mA}$		0.6 4	1 6	mA mA
		OFF MODE $V_i = 6\text{ V}$		50	100	$\mu\text{A}$
SVR	Supply Voltage Rejection	$I_o = 5\text{ mA}$ $V_i = 4.4\text{ V} \pm 1\text{ V}$ $f = 120\text{ Hz}$ $f = 1\text{ KHz}$ $f = 10\text{ KHz}$		75 72 55		dB dB dB
eN	Output Noise Voltage	$B = 10\text{ Hz to }100\text{ KHz}$		50		$\mu\text{V}$
$V_d(*)$	Dropout Voltage	$I_o = 250\text{ mA}$ $I_o = 250\text{ mA}$ $-40 < T_j < 125\text{ }^\circ\text{C}$		0.4	0.6 0.8	V V
$V_{il}$	Control Input Logic Low	$-40 < T_a < 125\text{ }^\circ\text{C}$			0.8	V
$V_{ih}$	Control Input Logic High	$-40 < T_a < 125\text{ }^\circ\text{C}$	2			V
$I_i$	Control Input Current	$V_i = 6\text{ V}$ , $V_c = 6\text{ V}$		10		$\mu\text{A}$
$C_o$	Output Bypass Capacitance	$\text{ESR} = 0.1\text{ to }10\text{ }\Omega$ $I_o = 0\text{ to }250\text{ mA}$	2	10		$\mu\text{F}$

(\*) For SO-8 package the maximum limit of load regulation and dropout is increased by 20mV

**ELECTRICAL CHARACTERISTICS FOR L4931ABxx27** (refer to the test circuits,  $T_j = 25\text{ }^\circ\text{C}$ ,  $C_i = 0.1\text{ }\mu\text{F}$ ,  $C_o = 2.2\text{ }\mu\text{F}$  unless otherwise specified)

Symbol	Parameter	Test Conditions	Min.	Typ.	Max.	Unit
$V_o$	Output Voltage	$I_o = 5\text{ mA}$ , $V_i = 4.7\text{ V}$	2.673	2.7	2.727	V
		$I_o = 5\text{ mA}$ , $V_i = 4.7\text{ V}$ $-25 < T_a < 85\text{ }^\circ\text{C}$	2.646		2.754	V
$V_i$	Operating Input Voltage	$I_o = 250\text{ mA}$			20	V
$I_{out}$	Output Current Limit			300		mA
$\Delta V_o$	Line Regulation	$V_i = 3.4\text{ to }20\text{ V}$ , $I_o = 0.5\text{ mA}$		3	15	mV
$\Delta V_o(*)$	Load Regulation	$V_i = 3.6\text{ V}$ $I_o = 0.5\text{ to }250\text{ mA}$		3	15	mV
$I_d$	Quiescent Current	ON MODE				
		$V_i = 3.6\text{ to }20\text{ V}$ $I_o = 0\text{ mA}$		0.6	1	mA
		$V_i = 3.6\text{ to }20\text{ V}$ $I_o = 250\text{ mA}$		4	6	mA
	OFF MODE $V_i = 6\text{ V}$		50	100	$\mu\text{A}$	
SVR	Supply Voltage Rejection	$I_o = 5\text{ mA}$ $V_i = 4.6\text{ V} \pm 1\text{ V}$				
		$f = 120\text{ Hz}$		74		dB
		$f = 1\text{ KHz}$		71		dB
		$f = 10\text{ KHz}$		55		dB
eN	Output Noise Voltage	$B = 10\text{ Hz to }100\text{ KHz}$		50		$\mu\text{V}$
$V_d(*)$	Dropout Voltage	$I_o = 250\text{ mA}$		0.4	0.6	V
		$I_o = 250\text{ mA}$ $-40 < T_j < 125\text{ }^\circ\text{C}$			0.8	V
$V_{il}$	Control Input Logic Low	$-40 < T_a < 125\text{ }^\circ\text{C}$			0.8	V
$V_{ih}$	Control Input Logic High	$-40 < T_a < 125\text{ }^\circ\text{C}$	2			V
$I_i$	Control Input Current	$V_i = 6\text{ V}$ , $V_c = 6\text{ V}$		10		$\mu\text{A}$
$C_o$	Output Bypass Capacitance	$\text{ESR} = 0.1\text{ to }10\text{ }\Omega$ $I_o = 0\text{ to }250\text{ mA}$	2	10		$\mu\text{F}$

**ELECTRICAL CHARACTERISTICS FOR L4931Cxx27** (refer to the test circuits,  $T_j = 25\text{ }^\circ\text{C}$ ,  $C_i = 0.1\text{ }\mu\text{F}$ ,  $C_o = 2.2\text{ }\mu\text{F}$  unless otherwise specified)

Symbol	Parameter	Test Conditions	Min.	Typ.	Max.	Unit
$V_o$	Output Voltage	$I_o = 5\text{ mA}$ , $V_i = 4.7\text{ V}$	2.646	2.7	2.754	V
		$I_o = 5\text{ mA}$ , $V_i = 4.7\text{ V}$ $-25 < T_a < 85\text{ }^\circ\text{C}$	2.592		2.808	V
$V_i$	Operating Input Voltage	$I_o = 250\text{ mA}$			20	V
$I_{out}$	Output Current Limit			300		mA
$\Delta V_o$	Line Regulation	$V_i = 3.5\text{ to }20\text{ V}$ , $I_o = 0.5\text{ mA}$		3	18	mV
$\Delta V_o(*)$	Load Regulation	$V_i = 3.7\text{ V}$ $I_o = 0.5\text{ to }250\text{ mA}$		3	18	mV
$I_d$	Quiescent Current	ON MODE				
		$V_i = 3.7\text{ to }20\text{ V}$ $I_o = 0\text{ mA}$		0.6	1	mA
		$V_i = 3.7\text{ to }20\text{ V}$ $I_o = 250\text{ mA}$		4	6	mA
	OFF MODE $V_i = 6\text{ V}$		50	100	$\mu\text{A}$	
SVR	Supply Voltage Rejection	$I_o = 5\text{ mA}$ $V_i = 4.7\text{ V} \pm 1\text{ V}$				
		$f = 120\text{ Hz}$		74		dB
		$f = 1\text{ KHz}$		71		dB
		$f = 10\text{ KHz}$		55		dB
eN	Output Noise Voltage	$B = 10\text{ Hz to }100\text{ KHz}$		50		$\mu\text{V}$
$V_d(*)$	Dropout Voltage	$I_o = 250\text{ mA}$		0.4	0.6	V
		$I_o = 250\text{ mA}$ $-40 < T_j < 125\text{ }^\circ\text{C}$			0.8	V
$V_{il}$	Control Input Logic Low	$-40 < T_a < 125\text{ }^\circ\text{C}$			0.8	V
$V_{ih}$	Control Input Logic High	$-40 < T_a < 125\text{ }^\circ\text{C}$	2			V
$I_i$	Control Input Current	$V_i = 6\text{ V}$ , $V_c = 6\text{ V}$		10		$\mu\text{A}$
$C_o$	Output Bypass Capacitance	$\text{ESR} = 0.1\text{ to }10\text{ }\Omega$ $I_o = 0\text{ to }250\text{ mA}$	2	10		$\mu\text{F}$

(\*) For SO-8 package the maximum limit of load regulation and dropout is increased by 20mV

## L4931 SERIES

**ELECTRICAL CHARACTERISTICS FOR L4931ABxx30** (refer to the test circuits,  $T_j = 25\text{ }^\circ\text{C}$ ,  $C_i = 0.1\text{ }\mu\text{F}$ ,  $C_o = 2.2\text{ }\mu\text{F}$  unless otherwise specified)

Symbol	Parameter	Test Conditions	Min.	Typ.	Max.	Unit
$V_o$	Output Voltage	$I_o = 5\text{ mA}$ , $V_i = 5\text{ V}$	2.97	3	3.03	V
		$I_o = 5\text{ mA}$ , $V_i = 5\text{ V}$ $-25 < T_a < 85\text{ }^\circ\text{C}$	2.94		3.06	V
$V_i$	Operating Input Voltage	$I_o = 250\text{ mA}$			20	V
$I_{out}$	Output Current Limit			300		mA
$\Delta V_o$	Line Regulation	$V_i = 3.7\text{ to }20\text{ V}$ , $I_o = 0.5\text{ mA}$		3	15	mV
$\Delta V_o(*)$	Load Regulation	$V_i = 3.9\text{ V}$ $I_o = 0.5\text{ to }250\text{ mA}$		3	15	mV
$I_d$	Quiescent Current	ON MODE				
		$V_i = 3.9\text{ to }20\text{ V}$ $I_o = 0\text{ mA}$		0.6	1	mA
		$V_i = 3.9\text{ to }20\text{ V}$ $I_o = 250\text{ mA}$		4	6	mA
	OFF MODE $V_i = 6\text{ V}$		50	100	$\mu\text{A}$	
SVR	Supply Voltage Rejection	$I_o = 5\text{ mA}$ $V_i = 4.9\text{ V} \pm 1\text{ V}$				
		$f = 120\text{ Hz}$		74		dB
		$f = 1\text{ KHz}$		71		dB
		$f = 10\text{ KHz}$		55		dB
eN	Output Noise Voltage	$B = 10\text{ Hz to }100\text{ KHz}$		50		$\mu\text{V}$
$V_d(*)$	Dropout Voltage	$I_o = 250\text{ mA}$		0.4	0.6	V
		$I_o = 250\text{ mA}$ $-40 < T_j < 125\text{ }^\circ\text{C}$			0.8	V
$V_{il}$	Control Input Logic Low	$-40 < T_a < 125\text{ }^\circ\text{C}$			0.8	V
$V_{ih}$	Control Input Logic High	$-40 < T_a < 125\text{ }^\circ\text{C}$	2			V
$I_i$	Control Input Current	$V_i = 6\text{ V}$ , $V_c = 6\text{ V}$		10		$\mu\text{A}$
$C_o$	Output Bypass Capacitance	$\text{ESR} = 0.1\text{ to }10\text{ }\Omega$ $I_o = 0\text{ to }250\text{ mA}$	2	10		$\mu\text{F}$

**ELECTRICAL CHARACTERISTICS FOR L4931Cxx30** (refer to the test circuits,  $T_j = 25\text{ }^\circ\text{C}$ ,  $C_i = 0.1\text{ }\mu\text{F}$ ,  $C_o = 2.2\text{ }\mu\text{F}$  unless otherwise specified)

Symbol	Parameter	Test Conditions	Min.	Typ.	Max.	Unit
$V_o$	Output Voltage	$I_o = 5\text{ mA}$ , $V_i = 5\text{ V}$	2.94	3	3.06	V
		$I_o = 5\text{ mA}$ , $V_i = 5\text{ V}$ $-25 < T_a < 85\text{ }^\circ\text{C}$	2.88		3.12	V
$V_i$	Operating Input Voltage	$I_o = 250\text{ mA}$			20	V
$I_{out}$	Output Current Limit			300		mA
$\Delta V_o$	Line Regulation	$V_i = 3.8\text{ to }20\text{ V}$ , $I_o = 0.5\text{ mA}$		3	18	mV
$\Delta V_o(*)$	Load Regulation	$V_i = 4\text{ V}$ $I_o = 0.5\text{ to }250\text{ mA}$		3	18	mV
$I_d$	Quiescent Current	ON MODE				
		$V_i = 4\text{ to }20\text{ V}$ $I_o = 0\text{ mA}$		0.6	1	mA
		$V_i = 4\text{ to }20\text{ V}$ $I_o = 250\text{ mA}$		4	6	mA
	OFF MODE $V_i = 6\text{ V}$		50	100	$\mu\text{A}$	
SVR	Supply Voltage Rejection	$I_o = 5\text{ mA}$ $V_i = 5\text{ V} \pm 1\text{ V}$				
		$f = 120\text{ Hz}$		74		dB
		$f = 1\text{ KHz}$		71		dB
		$f = 10\text{ KHz}$		55		dB
eN	Output Noise Voltage	$B = 10\text{ Hz to }100\text{ KHz}$		50		$\mu\text{V}$
$V_d(*)$	Dropout Voltage	$I_o = 250\text{ mA}$		0.4	0.6	V
		$I_o = 250\text{ mA}$ $-40 < T_j < 125\text{ }^\circ\text{C}$			0.8	V
$V_{il}$	Control Input Logic Low	$-40 < T_a < 125\text{ }^\circ\text{C}$			0.8	V
$V_{ih}$	Control Input Logic High	$-40 < T_a < 125\text{ }^\circ\text{C}$	2			V
$I_i$	Control Input Current	$V_i = 6\text{ V}$ , $V_c = 6\text{ V}$		10		$\mu\text{A}$
$C_o$	Output Bypass Capacitance	$\text{ESR} = 0.1\text{ to }10\text{ }\Omega$ $I_o = 0\text{ to }250\text{ mA}$	2	10		$\mu\text{F}$

(\*) For SO-8 package the maximum limit of load regulation and dropout is increased by 20mV



**ELECTRICAL CHARACTERISTICS FOR L4931ABxx33** (refer to the test circuits,  $T_j = 25\text{ }^\circ\text{C}$ ,  $C_i = 0.1\text{ }\mu\text{F}$ ,  $C_o = 2.2\text{ }\mu\text{F}$  unless otherwise specified)

Symbol	Parameter	Test Conditions	Min.	Typ.	Max.	Unit
$V_o$	Output Voltage	$I_o = 5\text{ mA}$ , $V_i = 5.3\text{ V}$ $I_o = 5\text{ mA}$ , $V_i = 5.3\text{ V}$ $-25 < T_a < 85\text{ }^\circ\text{C}$	3.267 3.234	3.3	3.333 3.366	V V
$V_i$	Operating Input Voltage	$I_o = 250\text{ mA}$			20	V
$I_{out}$	Output Current Limit			300		mA
$\Delta V_o$	Line Regulation	$V_i = 4\text{ to }20\text{ V}$ , $I_o = 0.5\text{ mA}$		3	15	mV
$\Delta V_o(*)$	Load Regulation	$V_i = 4.2\text{ V}$ $I_o = 0.5\text{ to }250\text{ mA}$		3	15	mV
$I_d$	Quiescent Current	ON MODE $V_i = 4.2\text{ to }20\text{ V}$ $I_o = 0\text{ mA}$ $V_i = 4.2\text{ to }20\text{ V}$ $I_o = 250\text{ mA}$		0.6 4	1 6	mA mA
		OFF MODE $V_i = 6\text{ V}$		50	100	$\mu\text{A}$
SVR	Supply Voltage Rejection	$I_o = 5\text{ mA}$ $V_i = 5.2\text{ V} \pm 1\text{ V}$ $f = 120\text{ Hz}$ $f = 1\text{ KHz}$ $f = 10\text{ KHz}$		73 70 55		dB dB dB
eN	Output Noise Voltage	$B = 10\text{ Hz to }100\text{ KHz}$		50		$\mu\text{V}$
$V_d(*)$	Dropout Voltage	$I_o = 250\text{ mA}$		0.4	0.6	V
		$I_o = 250\text{ mA}$ $-40 < T_j < 125\text{ }^\circ\text{C}$			0.8	V
$V_{il}$	Control Input Logic Low	$-40 < T_a < 125\text{ }^\circ\text{C}$			0.8	V
$V_{ih}$	Control Input Logic High	$-40 < T_a < 125\text{ }^\circ\text{C}$	2			V
$I_i$	Control Input Current	$V_i = 6\text{ V}$ , $V_c = 6\text{ V}$		10		$\mu\text{A}$
$C_o$	Output Bypass Capacitance	$\text{ESR} = 0.1\text{ to }10\text{ }\Omega$ $I_o = 0\text{ to }250\text{ mA}$	2	10		$\mu\text{F}$

**ELECTRICAL CHARACTERISTICS FOR L4931Cxx33** (refer to the test circuits,  $T_j = 25\text{ }^\circ\text{C}$ ,  $C_i = 0.1\text{ }\mu\text{F}$ ,  $C_o = 2.2\text{ }\mu\text{F}$  unless otherwise specified)

Symbol	Parameter	Test Conditions	Min.	Typ.	Max.	Unit
$V_o$	Output Voltage	$I_o = 5\text{ mA}$ , $V_i = 5.3\text{ V}$ $I_o = 5\text{ mA}$ , $V_i = 5.3\text{ V}$ $-25 < T_a < 85\text{ }^\circ\text{C}$	3.234 3.168	3.3	3.366 3.432	V V
$V_i$	Operating Input Voltage	$I_o = 250\text{ mA}$			20	V
$I_{out}$	Output Current Limit			300		mA
$\Delta V_o$	Line Regulation	$V_i = 4.1\text{ to }20\text{ V}$ , $I_o = 0.5\text{ mA}$		3	18	mV
$\Delta V_o(*)$	Load Regulation	$V_i = 4.3\text{ V}$ $I_o = 0.5\text{ to }250\text{ mA}$		3	18	mV
$I_d$	Quiescent Current	ON MODE $V_i = 4.3\text{ to }20\text{ V}$ $I_o = 0\text{ mA}$ $V_i = 4.3\text{ to }20\text{ V}$ $I_o = 250\text{ mA}$		0.6 4	1 6	mA mA
		OFF MODE $V_i = 6\text{ V}$		50	100	$\mu\text{A}$
SVR	Supply Voltage Rejection	$I_o = 5\text{ mA}$ $V_i = 5.3\text{ V} \pm 1\text{ V}$ $f = 120\text{ Hz}$ $f = 1\text{ KHz}$ $f = 10\text{ KHz}$		73 70 55		dB dB dB
eN	Output Noise Voltage	$B = 10\text{ Hz to }100\text{ KHz}$		50		$\mu\text{V}$
$V_d(*)$	Dropout Voltage	$I_o = 250\text{ mA}$		0.4	0.6	V
		$I_o = 250\text{ mA}$ $-40 < T_j < 125\text{ }^\circ\text{C}$			0.8	V
$V_{il}$	Control Input Logic Low	$-40 < T_a < 125\text{ }^\circ\text{C}$			0.8	V
$V_{ih}$	Control Input Logic High	$-40 < T_a < 125\text{ }^\circ\text{C}$	2			V
$I_i$	Control Input Current	$V_i = 6\text{ V}$ , $V_c = 6\text{ V}$		10		$\mu\text{A}$
$C_o$	Output Bypass Capacitance	$\text{ESR} = 0.1\text{ to }10\text{ }\Omega$ $I_o = 0\text{ to }250\text{ mA}$	2	10		$\mu\text{F}$

(\*) For SO-8 package the maximum limit of load regulation and dropout is increased by 20mV

## L4931 SERIES

**ELECTRICAL CHARACTERISTICS FOR L4931ABxx35** (refer to the test circuits,  $T_j = 25\text{ }^\circ\text{C}$ ,  $C_i = 0.1\text{ }\mu\text{F}$ ,  $C_o = 2.2\text{ }\mu\text{F}$  unless otherwise specified)

Symbol	Parameter	Test Conditions	Min.	Typ.	Max.	Unit
$V_o$	Output Voltage	$I_o = 5\text{ mA}$ , $V_i = 5.5\text{ V}$ $I_o = 5\text{ mA}$ , $V_i = 5.5\text{ V}$ $-25 < T_a < 85\text{ }^\circ\text{C}$	3.465 3.43	3.5	3.535 3.57	V V
$V_i$	Operating Input Voltage	$I_o = 250\text{ mA}$			20	V
$I_{out}$	Output Current Limit			300		mA
$\Delta V_o$	Line Regulation	$V_i = 4.2\text{ to }20\text{ V}$ , $I_o = 0.5\text{ mA}$		3	15	mV
$\Delta V_o(*)$	Load Regulation	$V_i = 4.4\text{ V}$ $I_o = 0.5\text{ to }250\text{ mA}$		3	15	mV
$I_d$	Quiescent Current	ON MODE $V_i = 4.4\text{ to }20\text{ V}$ $I_o = 0\text{ mA}$ $V_i = 4.4\text{ to }20\text{ V}$ $I_o = 250\text{ mA}$		0.6 4	1 6	mA mA
		OFF MODE $V_i = 6\text{ V}$		50	100	$\mu\text{A}$
SVR	Supply Voltage Rejection	$I_o = 5\text{ mA}$ $V_i = 5.4\text{ V} \pm 1\text{ V}$ $f = 120\text{ Hz}$ $f = 1\text{ KHz}$ $f = 10\text{ KHz}$		73 70 55		dB dB dB
eN	Output Noise Voltage	$B = 10\text{ Hz to }100\text{ KHz}$		50		$\mu\text{V}$
$V_d(*)$	Dropout Voltage	$I_o = 250\text{ mA}$		0.4	0.6	V
		$I_o = 250\text{ mA}$ $-40 < T_j < 125\text{ }^\circ\text{C}$			0.8	V
$V_{il}$	Control Input Logic Low	$-40 < T_a < 125\text{ }^\circ\text{C}$			0.8	V
$V_{ih}$	Control Input Logic High	$-40 < T_a < 125\text{ }^\circ\text{C}$	2			V
$I_i$	Control Input Current	$V_i = 6\text{ V}$ , $V_c = 6\text{ V}$		10		$\mu\text{A}$
$C_o$	Output Bypass Capacitance	ESR = $0.1\text{ to }10\text{ }\Omega$ $I_o = 0\text{ to }250\text{ mA}$	2	10		$\mu\text{F}$

**ELECTRICAL CHARACTERISTICS FOR L4931Cxx35** (refer to the test circuits,  $T_j = 25\text{ }^\circ\text{C}$ ,  $C_i = 0.1\text{ }\mu\text{F}$ ,  $C_o = 2.2\text{ }\mu\text{F}$  unless otherwise specified)

Symbol	Parameter	Test Conditions	Min.	Typ.	Max.	Unit
$V_o$	Output Voltage	$I_o = 5\text{ mA}$ , $V_i = 5.5\text{ V}$ $I_o = 5\text{ mA}$ , $V_i = 5.5\text{ V}$ $-25 < T_a < 85\text{ }^\circ\text{C}$	3.43 3.36	3.5	3.57 3.64	V V
$V_i$	Operating Input Voltage	$I_o = 250\text{ mA}$			20	V
$I_{out}$	Output Current Limit			300		mA
$\Delta V_o$	Line Regulation	$V_i = 4.3\text{ to }20\text{ V}$ , $I_o = 0.5\text{ mA}$		3	18	mV
$\Delta V_o(*)$	Load Regulation	$V_i = 4.5\text{ V}$ $I_o = 0.5\text{ to }250\text{ mA}$		3	18	mV
$I_d$	Quiescent Current	ON MODE $V_i = 4.5\text{ to }20\text{ V}$ $I_o = 0\text{ mA}$ $V_i = 4.5\text{ to }20\text{ V}$ $I_o = 250\text{ mA}$		0.6 4	1 6	mA mA
		OFF MODE $V_i = 6\text{ V}$		50	100	$\mu\text{A}$
SVR	Supply Voltage Rejection	$I_o = 5\text{ mA}$ $V_i = 5.5\text{ V} \pm 1\text{ V}$ $f = 120\text{ Hz}$ $f = 1\text{ KHz}$ $f = 10\text{ KHz}$		73 70 55		dB dB dB
eN	Output Noise Voltage	$B = 10\text{ Hz to }100\text{ KHz}$		50		$\mu\text{V}$
$V_d(*)$	Dropout Voltage	$I_o = 250\text{ mA}$		0.4	0.6	V
		$I_o = 250\text{ mA}$ $-40 < T_j < 125\text{ }^\circ\text{C}$			0.8	V
$V_{il}$	Control Input Logic Low	$-40 < T_a < 125\text{ }^\circ\text{C}$			0.8	V
$V_{ih}$	Control Input Logic High	$-40 < T_a < 125\text{ }^\circ\text{C}$	2			V
$I_i$	Control Input Current	$V_i = 6\text{ V}$ , $V_c = 6\text{ V}$		10		$\mu\text{A}$
$C_o$	Output Bypass Capacitance	ESR = $0.1\text{ to }10\text{ }\Omega$ $I_o = 0\text{ to }250\text{ mA}$	2	10		$\mu\text{F}$

(\*) For SO-8 package the maximum limit of load regulation and dropout is increased by 20mV

**ELECTRICAL CHARACTERISTICS FOR L4931ABxx40** (refer to the test circuits,  $T_j = 25\text{ }^\circ\text{C}$ ,  $C_i = 0.1\text{ }\mu\text{F}$ ,  $C_o = 2.2\text{ }\mu\text{F}$  unless otherwise specified)

Symbol	Parameter	Test Conditions	Min.	Typ.	Max.	Unit
$V_o$	Output Voltage	$I_o = 5\text{ mA}$ , $V_i = 6\text{ V}$	3.96	4	4.04	V
		$I_o = 5\text{ mA}$ , $V_i = 6\text{ V}$ $-25 < T_a < 85\text{ }^\circ\text{C}$	3.92		4.08	V
$V_i$	Operating Input Voltage	$I_o = 250\text{ mA}$			20	V
$I_{out}$	Output Current Limit			300		mA
$\Delta V_o$	Line Regulation	$V_i = 4.7\text{ to }20\text{ V}$ , $I_o = 0.5\text{ mA}$		3.5	17.5	mV
$\Delta V_o(*)$	Load Regulation	$V_i = 4.9\text{ V}$ $I_o = 0.5\text{ to }250\text{ mA}$		3	15	mV
$I_d$	Quiescent Current	ON MODE				
		$V_i = 4.9\text{ to }20\text{ V}$ $I_o = 0\text{ mA}$		0.6	1	mA
		$V_i = 4.9\text{ to }20\text{ V}$ $I_o = 250\text{ mA}$		4	6	mA
	OFF MODE $V_i = 6\text{ V}$		50	100	$\mu\text{A}$	
SVR	Supply Voltage Rejection	$I_o = 5\text{ mA}$ $V_i = 5.9\text{ V} \pm 1\text{ V}$				
		$f = 120\text{ Hz}$		72		dB
		$f = 1\text{ KHz}$		69		dB
		$f = 10\text{ KHz}$		55		dB
eN	Output Noise Voltage	$B = 10\text{ Hz to }100\text{ KHz}$		50		$\mu\text{V}$
$V_d(*)$	Dropout Voltage	$I_o = 250\text{ mA}$		0.4	0.6	V
		$I_o = 250\text{ mA}$ $-40 < T_j < 125\text{ }^\circ\text{C}$			0.8	V
$V_{il}$	Control Input Logic Low	$-40 < T_a < 125\text{ }^\circ\text{C}$			0.8	V
$V_{ih}$	Control Input Logic High	$-40 < T_a < 125\text{ }^\circ\text{C}$	2			V
$I_i$	Control Input Current	$V_i = 6\text{ V}$ , $V_c = 6\text{ V}$		10		$\mu\text{A}$
$C_o$	Output Bypass Capacitance	$\text{ESR} = 0.1\text{ to }10\text{ }\Omega$ $I_o = 0\text{ to }250\text{ mA}$	2	10		$\mu\text{F}$

**ELECTRICAL CHARACTERISTICS FOR L4931Cxx40** (refer to the test circuits,  $T_j = 25\text{ }^\circ\text{C}$ ,  $C_i = 0.1\text{ }\mu\text{F}$ ,  $C_o = 2.2\text{ }\mu\text{F}$  unless otherwise specified)

Symbol	Parameter	Test Conditions	Min.	Typ.	Max.	Unit
$V_o$	Output Voltage	$I_o = 5\text{ mA}$ , $V_i = 6\text{ V}$	3.92	4	4.08	V
		$I_o = 5\text{ mA}$ , $V_i = 6\text{ V}$ $-25 < T_a < 85\text{ }^\circ\text{C}$	3.84		4.16	V
$V_i$	Operating Input Voltage	$I_o = 250\text{ mA}$			20	V
$I_{out}$	Output Current Limit			300		mA
$\Delta V_o$	Line Regulation	$V_i = 4.8\text{ to }20\text{ V}$ , $I_o = 0.5\text{ mA}$		3.5	21	mV
$\Delta V_o(*)$	Load Regulation	$V_i = 5\text{ V}$ $I_o = 0.5\text{ to }250\text{ mA}$		3	18	mV
$I_d$	Quiescent Current	ON MODE				
		$V_i = 5\text{ to }20\text{ V}$ $I_o = 0\text{ mA}$		0.6	1	mA
		$V_i = 5\text{ to }20\text{ V}$ $I_o = 250\text{ mA}$		4	6	mA
	OFF MODE $V_i = 6\text{ V}$		50	100	$\mu\text{A}$	
SVR	Supply Voltage Rejection	$I_o = 5\text{ mA}$ $V_i = 6\text{ V} \pm 1\text{ V}$				
		$f = 120\text{ Hz}$		72		dB
		$f = 1\text{ KHz}$		69		dB
		$f = 10\text{ KHz}$		55		dB
eN	Output Noise Voltage	$B = 10\text{ Hz to }100\text{ KHz}$		50		$\mu\text{V}$
$V_d(*)$	Dropout Voltage	$I_o = 250\text{ mA}$		0.4	0.6	V
		$I_o = 250\text{ mA}$ $-40 < T_j < 125\text{ }^\circ\text{C}$			0.8	V
$V_{il}$	Control Input Logic Low	$-40 < T_a < 125\text{ }^\circ\text{C}$			0.8	V
$V_{ih}$	Control Input Logic High	$-40 < T_a < 125\text{ }^\circ\text{C}$	2			V
$I_i$	Control Input Current	$V_i = 6\text{ V}$ , $V_c = 6\text{ V}$		10		$\mu\text{A}$
$C_o$	Output Bypass Capacitance	$\text{ESR} = 0.1\text{ to }10\text{ }\Omega$ $I_o = 0\text{ to }250\text{ mA}$	2	10		$\mu\text{F}$

(\*) For SO-8 package the maximum limit of load regulation and dropout is increased by 20mV

## L4931 SERIES

**ELECTRICAL CHARACTERISTICS FOR L4931ABxx45** (refer to the test circuits,  $T_j = 25\text{ }^\circ\text{C}$ ,  $C_i = 0.1\text{ }\mu\text{F}$ ,  $C_o = 2.2\text{ }\mu\text{F}$  unless otherwise specified)

Symbol	Parameter	Test Conditions	Min.	Typ.	Max.	Unit
$V_o$	Output Voltage	$I_o = 5\text{ mA}$ , $V_i = 6.5\text{ V}$ $I_o = 5\text{ mA}$ , $V_i = 6.5\text{ V}$ $-25 < T_a < 85\text{ }^\circ\text{C}$	4.455 4.41	4.5	4.545 4.59	V V
$V_i$	Operating Input Voltage	$I_o = 250\text{ mA}$			20	V
$I_{out}$	Output Current Limit			300		mA
$\Delta V_o$	Line Regulation	$V_i = 5.2\text{ to }20\text{ V}$ , $I_o = 0.5\text{ mA}$		3.5	17.5	mV
$\Delta V_o(*)$	Load Regulation	$V_i = 5.4\text{ V}$ $I_o = 0.5\text{ to }250\text{ mA}$		3	15	mV
$I_d$	Quiescent Current	ON MODE $V_i = 5.4\text{ to }20\text{ V}$ $I_o = 0\text{ mA}$ $V_i = 5.4\text{ to }20\text{ V}$ $I_o = 250\text{ mA}$		0.6 4	1 6	mA mA
		OFF MODE $V_i = 6\text{ V}$		50	100	$\mu\text{A}$
SVR	Supply Voltage Rejection	$I_o = 5\text{ mA}$ $V_i = 6.4\text{ V} \pm 1\text{ V}$ $f = 120\text{ Hz}$ $f = 1\text{ KHz}$ $f = 10\text{ KHz}$		71 68 55		dB dB dB
eN	Output Noise Voltage	$B = 10\text{ Hz to }100\text{ KHz}$		50		$\mu\text{V}$
$V_d(*)$	Dropout Voltage	$I_o = 250\text{ mA}$ $I_o = 250\text{ mA}$ $-40 < T_j < 125\text{ }^\circ\text{C}$		0.4	0.6 0.8	V V
$V_{il}$	Control Input Logic Low	$-40 < T_a < 125\text{ }^\circ\text{C}$			0.8	V
$V_{ih}$	Control Input Logic High	$-40 < T_a < 125\text{ }^\circ\text{C}$	2			V
$I_i$	Control Input Current	$V_i = 6\text{ V}$ , $V_c = 6\text{ V}$		10		$\mu\text{A}$
$C_o$	Output Bypass Capacitance	$\text{ESR} = 0.1\text{ to }10\text{ }\Omega$ $I_o = 0\text{ to }250\text{ mA}$	2	10		$\mu\text{F}$

**ELECTRICAL CHARACTERISTICS FOR L4931Cxx45** (refer to the test circuits,  $T_j = 25\text{ }^\circ\text{C}$ ,  $C_i = 0.1\text{ }\mu\text{F}$ ,  $C_o = 2.2\text{ }\mu\text{F}$  unless otherwise specified)

Symbol	Parameter	Test Conditions	Min.	Typ.	Max.	Unit
$V_o$	Output Voltage	$I_o = 5\text{ mA}$ , $V_i = 6.5\text{ V}$ $I_o = 5\text{ mA}$ , $V_i = 6.5\text{ V}$ $-25 < T_a < 85\text{ }^\circ\text{C}$	4.41 4.32	4.5	4.59 4.68	V V
$V_i$	Operating Input Voltage	$I_o = 250\text{ mA}$			20	V
$I_{out}$	Output Current Limit			300		mA
$\Delta V_o$	Line Regulation	$V_i = 5.3\text{ to }20\text{ V}$ , $I_o = 0.5\text{ mA}$		3.5	21	mV
$\Delta V_o(*)$	Load Regulation	$V_i = 5.5\text{ V}$ $I_o = 0.5\text{ to }250\text{ mA}$		3	18	mV
$I_d$	Quiescent Current	ON MODE $V_i = 5.5\text{ to }20\text{ V}$ $I_o = 0\text{ mA}$ $V_i = 5.5\text{ to }20\text{ V}$ $I_o = 250\text{ mA}$		0.6 4	1 6	mA mA
		OFF MODE $V_i = 6\text{ V}$		50	100	$\mu\text{A}$
SVR	Supply Voltage Rejection	$I_o = 5\text{ mA}$ $V_i = 6.5\text{ V} \pm 1\text{ V}$ $f = 120\text{ Hz}$ $f = 1\text{ KHz}$ $f = 10\text{ KHz}$		71 68 55		dB dB dB
eN	Output Noise Voltage	$B = 10\text{ Hz to }100\text{ KHz}$		50		$\mu\text{V}$
$V_d(*)$	Dropout Voltage	$I_o = 250\text{ mA}$ $I_o = 250\text{ mA}$ $-40 < T_j < 125\text{ }^\circ\text{C}$		0.4	0.6 0.8	V V
$V_{il}$	Control Input Logic Low	$-40 < T_a < 125\text{ }^\circ\text{C}$			0.8	V
$V_{ih}$	Control Input Logic High	$-40 < T_a < 125\text{ }^\circ\text{C}$	2			V
$I_i$	Control Input Current	$V_i = 6\text{ V}$ , $V_c = 6\text{ V}$		10		$\mu\text{A}$
$C_o$	Output Bypass Capacitance	$\text{ESR} = 0.1\text{ to }10\text{ }\Omega$ $I_o = 0\text{ to }250\text{ mA}$	2	10		$\mu\text{F}$

(\*) For SO-8 package the maximum limit of load regulation and dropout is increased by 20mV

**ELECTRICAL CHARACTERISTICS FOR L4931ABxx47** (refer to the test circuits,  $T_j = 25\text{ }^\circ\text{C}$ ,  $C_i = 0.1\text{ }\mu\text{F}$ ,  $C_o = 2.2\text{ }\mu\text{F}$  unless otherwise specified)

Symbol	Parameter	Test Conditions	Min.	Typ.	Max.	Unit
$V_o$	Output Voltage	$I_o = 5\text{ mA}$ , $V_i = 6.7\text{ V}$	4.653	4.7	4.747	V
		$I_o = 5\text{ mA}$ , $V_i = 6.7\text{ V}$ $-25 < T_a < 85\text{ }^\circ\text{C}$	4.606		4.794	V
$V_i$	Operating Input Voltage	$I_o = 250\text{ mA}$			20	V
$I_{out}$	Output Current Limit			300		mA
$\Delta V_o$	Line Regulation	$V_i = 5.4\text{ to }20\text{ V}$ , $I_o = 0.5\text{ mA}$		3.5	17.5	mV
$\Delta V_o(*)$	Load Regulation	$V_i = 5.6\text{ V}$ $I_o = 0.5\text{ to }250\text{ mA}$		3	15	mV
$I_d$	Quiescent Current	ON MODE				
		$V_i = 5.6\text{ to }20\text{ V}$ $I_o = 0\text{ mA}$		0.6	1	mA
		$V_i = 5.6\text{ to }20\text{ V}$ $I_o = 250\text{ mA}$		4	6	mA
	OFF MODE $V_i = 6\text{ V}$		50	100	$\mu\text{A}$	
SVR	Supply Voltage Rejection	$I_o = 5\text{ mA}$ $V_i = 6.6\text{ V} \pm 1\text{ V}$				
		$f = 120\text{ Hz}$		71		dB
		$f = 1\text{ KHz}$		68		dB
		$f = 10\text{ KHz}$		55		dB
eN	Output Noise Voltage	$B = 10\text{ Hz to }100\text{ KHz}$		50		$\mu\text{V}$
$V_d(*)$	Dropout Voltage	$I_o = 250\text{ mA}$		0.4	0.6	V
		$I_o = 250\text{ mA}$ $-40 < T_j < 125\text{ }^\circ\text{C}$			0.8	V
$V_{il}$	Control Input Logic Low	$-40 < T_a < 125\text{ }^\circ\text{C}$			0.8	V
$V_{ih}$	Control Input Logic High	$-40 < T_a < 125\text{ }^\circ\text{C}$	2			V
$I_i$	Control Input Current	$V_i = 6\text{ V}$ , $V_c = 6\text{ V}$		10		$\mu\text{A}$
$C_o$	Output Bypass Capacitance	$\text{ESR} = 0.1\text{ to }10\text{ }\Omega$ $I_o = 0\text{ to }250\text{ mA}$	2	10		$\mu\text{F}$

**ELECTRICAL CHARACTERISTICS FOR L4931Cxx47** (refer to the test circuits,  $T_j = 25\text{ }^\circ\text{C}$ ,  $C_i = 0.1\text{ }\mu\text{F}$ ,  $C_o = 2.2\text{ }\mu\text{F}$  unless otherwise specified)

Symbol	Parameter	Test Conditions	Min.	Typ.	Max.	Unit
$V_o$	Output Voltage	$I_o = 5\text{ mA}$ , $V_i = 6.7\text{ V}$	4.606	4.7	4.794	V
		$I_o = 5\text{ mA}$ , $V_i = 6.7\text{ V}$ $-25 < T_a < 85\text{ }^\circ\text{C}$	4.512		4.888	V
$V_i$	Operating Input Voltage	$I_o = 250\text{ mA}$			20	V
$I_{out}$	Output Current Limit			300		mA
$\Delta V_o$	Line Regulation	$V_i = 5.5\text{ to }20\text{ V}$ , $I_o = 0.5\text{ mA}$		3.5	21	mV
$\Delta V_o(*)$	Load Regulation	$V_i = 5.7\text{ V}$ $I_o = 0.5\text{ to }250\text{ mA}$		3	18	mV
$I_d$	Quiescent Current	ON MODE				
		$V_i = 5.7\text{ to }20\text{ V}$ $I_o = 0\text{ mA}$		0.6	1	mA
		$V_i = 5.7\text{ to }20\text{ V}$ $I_o = 250\text{ mA}$		4	6	mA
	OFF MODE $V_i = 6\text{ V}$		50	100	$\mu\text{A}$	
SVR	Supply Voltage Rejection	$I_o = 5\text{ mA}$ $V_i = 6.7\text{ V} \pm 1\text{ V}$				
		$f = 120\text{ Hz}$		71		dB
		$f = 1\text{ KHz}$		68		dB
		$f = 10\text{ KHz}$		55		dB
eN	Output Noise Voltage	$B = 10\text{ Hz to }100\text{ KHz}$		50		$\mu\text{V}$
$V_d(*)$	Dropout Voltage	$I_o = 250\text{ mA}$		0.4	0.6	V
		$I_o = 250\text{ mA}$ $-40 < T_j < 125\text{ }^\circ\text{C}$			0.8	V
$V_{il}$	Control Input Logic Low	$-40 < T_a < 125\text{ }^\circ\text{C}$			0.8	V
$V_{ih}$	Control Input Logic High	$-40 < T_a < 125\text{ }^\circ\text{C}$	2			V
$I_i$	Control Input Current	$V_i = 6\text{ V}$ , $V_c = 6\text{ V}$		10		$\mu\text{A}$
$C_o$	Output Bypass Capacitance	$\text{ESR} = 0.1\text{ to }10\text{ }\Omega$ $I_o = 0\text{ to }250\text{ mA}$	2	10		$\mu\text{F}$

(\*) For SO-8 package the maximum limit of load regulation and dropout is increased by 20mV

## L4931 SERIES

**ELECTRICAL CHARACTERISTICS FOR L4931ABxx50** (refer to the test circuits,  $T_j = 25\text{ }^\circ\text{C}$ ,  $C_i = 0.1\text{ }\mu\text{F}$ ,  $C_o = 2.2\text{ }\mu\text{F}$  unless otherwise specified)

Symbol	Parameter	Test Conditions	Min.	Typ.	Max.	Unit
$V_o$	Output Voltage	$I_o = 5\text{ mA}$ , $V_i = 7\text{ V}$ $I_o = 5\text{ mA}$ , $V_i = 7\text{ V}$ $-25 < T_a < 85\text{ }^\circ\text{C}$	4.95 4.9	5	5.05 5.1	V V
$V_i$	Operating Input Voltage	$I_o = 250\text{ mA}$			20	V
$I_{out}$	Output Current Limit			300		mA
$\Delta V_o$	Line Regulation	$V_i = 5.8\text{ to }20\text{ V}$ , $I_o = 0.5\text{ mA}$		3.5	17.5	mV
$\Delta V_o(*)$	Load Regulation	$V_i = 6\text{ V}$ $I_o = 0.5\text{ to }250\text{ mA}$		3	15	mV
$I_d$	Quiescent Current	ON MODE $V_i = 6\text{ to }20\text{ V}$ $I_o = 0\text{ mA}$ $V_i = 6\text{ to }20\text{ V}$ $I_o = 250\text{ mA}$		0.6 4	1 6	mA mA
		OFF MODE $V_i = 6\text{ V}$		50	100	$\mu\text{A}$
SVR	Supply Voltage Rejection	$I_o = 5\text{ mA}$ $V_i = 7\text{ V} \pm 1\text{ V}$ $f = 120\text{ Hz}$ $f = 1\text{ KHz}$ $f = 10\text{ KHz}$		70 67 55		dB dB dB
eN	Output Noise Voltage	$B = 10\text{ Hz to }100\text{ KHz}$		50		$\mu\text{V}$
$V_d(*)$	Dropout Voltage	$I_o = 250\text{ mA}$ $I_o = 250\text{ mA}$ $-40 < T_j < 125\text{ }^\circ\text{C}$		0.4	0.6 0.8	V V
$V_{il}$	Control Input Logic Low	$-40 < T_a < 125\text{ }^\circ\text{C}$			0.8	V
$V_{ih}$	Control Input Logic High	$-40 < T_a < 125\text{ }^\circ\text{C}$	2			V
$I_i$	Control Input Current	$V_i = 6\text{ V}$ , $V_c = 6\text{ V}$		10		$\mu\text{A}$
$C_o$	Output Bypass Capacitance	$\text{ESR} = 0.1\text{ to }10\text{ }\Omega$ $I_o = 0\text{ to }250\text{ mA}$	2	10		$\mu\text{F}$

**ELECTRICAL CHARACTERISTICS FOR L4931Cxx50** (refer to the test circuits,  $T_j = 25\text{ }^\circ\text{C}$ ,  $C_i = 0.1\text{ }\mu\text{F}$ ,  $C_o = 2.2\text{ }\mu\text{F}$  unless otherwise specified)

Symbol	Parameter	Test Conditions	Min.	Typ.	Max.	Unit
$V_o$	Output Voltage	$I_o = 5\text{ mA}$ , $V_i = 7\text{ V}$ $I_o = 5\text{ mA}$ , $V_i = 7\text{ V}$ $-25 < T_a < 85\text{ }^\circ\text{C}$	4.9 4.8	5	5.1 5.2	V V
$V_i$	Operating Input Voltage	$I_o = 250\text{ mA}$			20	V
$I_{out}$	Output Current Limit			300		mA
$\Delta V_o$	Line Regulation	$V_i = 5.8\text{ to }20\text{ V}$ , $I_o = 0.5\text{ mA}$		3.5	21	mV
$\Delta V_o(*)$	Load Regulation	$V_i = 6\text{ V}$ $I_o = 0.5\text{ to }250\text{ mA}$		3	18	mV
$I_d$	Quiescent Current	ON MODE $V_i = 6\text{ to }20\text{ V}$ $I_o = 0\text{ mA}$ $V_i = 6\text{ to }20\text{ V}$ $I_o = 250\text{ mA}$		0.6 4	1 6	mA mA
		OFF MODE $V_i = 6\text{ V}$		50	100	$\mu\text{A}$
SVR	Supply Voltage Rejection	$I_o = 5\text{ mA}$ $V_i = 7\text{ V} \pm 1\text{ V}$ $f = 120\text{ Hz}$ $f = 1\text{ KHz}$ $f = 10\text{ KHz}$		70 67 55		dB dB dB
eN	Output Noise Voltage	$B = 10\text{ Hz to }100\text{ KHz}$		50		$\mu\text{V}$
$V_d(*)$	Dropout Voltage	$I_o = 250\text{ mA}$ $I_o = 250\text{ mA}$ $-40 < T_j < 125\text{ }^\circ\text{C}$		0.4	0.6 0.8	V V
$V_{il}$	Control Input Logic Low	$-40 < T_a < 125\text{ }^\circ\text{C}$			0.8	V
$V_{ih}$	Control Input Logic High	$-40 < T_a < 125\text{ }^\circ\text{C}$	2			V
$I_i$	Control Input Current	$V_i = 6\text{ V}$ , $V_c = 6\text{ V}$		10		$\mu\text{A}$
$C_o$	Output Bypass Capacitance	$\text{ESR} = 0.1\text{ to }10\text{ }\Omega$ $I_o = 0\text{ to }250\text{ mA}$	2	10		$\mu\text{F}$

(\*) For SO-8 package the maximum limit of load regulation and dropout is increased by 20mV

**ELECTRICAL CHARACTERISTICS FOR L4931ABxx52** (refer to the test circuits,  $T_j = 25\text{ }^\circ\text{C}$ ,  $C_i = 0.1\text{ }\mu\text{F}$ ,  $C_o = 2.2\text{ }\mu\text{F}$  unless otherwise specified)

Symbol	Parameter	Test Conditions	Min.	Typ.	Max.	Unit
$V_o$	Output Voltage	$I_o = 5\text{ mA}$ , $V_i = 7.2\text{ V}$	5.148	5.2	5.252	V
		$I_o = 5\text{ mA}$ , $V_i = 7.2\text{ V}$ $-25 < T_a < 85\text{ }^\circ\text{C}$	5.096		5.304	V
$V_i$	Operating Input Voltage	$I_o = 250\text{ mA}$			20	V
$I_{out}$	Output Current Limit			300		mA
$\Delta V_o$	Line Regulation	$V_i = 6\text{ to }20\text{ V}$ , $I_o = 0.5\text{ mA}$		3.5	17.5	mV
$\Delta V_o(*)$	Load Regulation	$V_i = 6.2\text{ V}$ $I_o = 0.5\text{ to }250\text{ mA}$		3	15	mV
$I_d$	Quiescent Current	ON MODE		0.6	1	mA
		$V_i = 6.2\text{ to }20\text{ V}$ $I_o = 0\text{ mA}$				
		$V_i = 6.2\text{ to }20\text{ V}$ $I_o = 250\text{ mA}$		4	6	mA
	OFF MODE $V_i = 6\text{ V}$		50	100	$\mu\text{A}$	
SVR	Supply Voltage Rejection	$I_o = 5\text{ mA}$ $V_i = 7.2\text{ V} \pm 1\text{ V}$		70		dB
		$f = 120\text{ Hz}$		67		
		$f = 1\text{ KHz}$		55		
		$f = 10\text{ KHz}$				
eN	Output Noise Voltage	$B = 10\text{ Hz to }100\text{ KHz}$		50		$\mu\text{V}$
$V_d(*)$	Dropout Voltage	$I_o = 250\text{ mA}$		0.4	0.6	V
		$I_o = 250\text{ mA}$ $-40 < T_j < 125\text{ }^\circ\text{C}$			0.8	V
$V_{il}$	Control Input Logic Low	$-40 < T_a < 125\text{ }^\circ\text{C}$			0.8	V
$V_{ih}$	Control Input Logic High	$-40 < T_a < 125\text{ }^\circ\text{C}$	2			V
$I_i$	Control Input Current	$V_i = 6\text{ V}$ , $V_c = 6\text{ V}$		10		$\mu\text{A}$
$C_o$	Output Bypass Capacitance	$\text{ESR} = 0.1\text{ to }10\text{ }\Omega$ $I_o = 0\text{ to }250\text{ mA}$	2	10		$\mu\text{F}$

**ELECTRICAL CHARACTERISTICS FOR L4931Cxx52** (refer to the test circuits,  $T_j = 25\text{ }^\circ\text{C}$ ,  $C_i = 0.1\text{ }\mu\text{F}$ ,  $C_o = 2.2\text{ }\mu\text{F}$  unless otherwise specified)

Symbol	Parameter	Test Conditions	Min.	Typ.	Max.	Unit
$V_o$	Output Voltage	$I_o = 5\text{ mA}$ , $V_i = 7.2\text{ V}$	5.096	5.2	5.304	V
		$I_o = 5\text{ mA}$ , $V_i = 7.2\text{ V}$ $-25 < T_a < 85\text{ }^\circ\text{C}$	4.992		5.408	V
$V_i$	Operating Input Voltage	$I_o = 250\text{ mA}$			20	V
$I_{out}$	Output Current Limit			300		mA
$\Delta V_o$	Line Regulation	$V_i = 6\text{ to }20\text{ V}$ , $I_o = 0.5\text{ mA}$		3.5	21	mV
$\Delta V_o(*)$	Load Regulation	$V_i = 6.2\text{ V}$ $I_o = 0.5\text{ to }250\text{ mA}$		3	18	mV
$I_d$	Quiescent Current	ON MODE		0.6	1	mA
		$V_i = 6.2\text{ to }20\text{ V}$ $I_o = 0\text{ mA}$				
		$V_i = 6.2\text{ to }20\text{ V}$ $I_o = 250\text{ mA}$		4	6	mA
	OFF MODE $V_i = 6\text{ V}$		50	100	$\mu\text{A}$	
SVR	Supply Voltage Rejection	$I_o = 5\text{ mA}$ $V_i = 7.2\text{ V} \pm 1\text{ V}$		70		dB
		$f = 120\text{ Hz}$		67		
		$f = 1\text{ KHz}$		55		
		$f = 10\text{ KHz}$				
eN	Output Noise Voltage	$B = 10\text{ Hz to }100\text{ KHz}$		50		$\mu\text{V}$
$V_d(*)$	Dropout Voltage	$I_o = 250\text{ mA}$		0.4	0.6	V
		$I_o = 250\text{ mA}$ $-40 < T_j < 125\text{ }^\circ\text{C}$			0.8	V
$V_{il}$	Control Input Logic Low	$-40 < T_a < 125\text{ }^\circ\text{C}$			0.8	V
$V_{ih}$	Control Input Logic High	$-40 < T_a < 125\text{ }^\circ\text{C}$	2			V
$I_i$	Control Input Current	$V_i = 6\text{ V}$ , $V_c = 6\text{ V}$		10		$\mu\text{A}$
$C_o$	Output Bypass Capacitance	$\text{ESR} = 0.1\text{ to }10\text{ }\Omega$ $I_o = 0\text{ to }250\text{ mA}$	2	10		$\mu\text{F}$

(\*) For SO-8 package the maximum limit of load regulation and dropout is increased by 20mV

## L4931 SERIES

**ELECTRICAL CHARACTERISTICS FOR L4931ABxx55** (refer to the test circuits,  $T_j = 25\text{ }^\circ\text{C}$ ,  $C_i = 0.1\text{ }\mu\text{F}$ ,  $C_o = 2.2\text{ }\mu\text{F}$  unless otherwise specified)

Symbol	Parameter	Test Conditions	Min.	Typ.	Max.	Unit
$V_o$	Output Voltage	$I_o = 5\text{ mA}$ , $V_i = 7.5\text{ V}$ $I_o = 5\text{ mA}$ , $V_i = 7.5\text{ V}$ $-25 < T_a < 85\text{ }^\circ\text{C}$	5.445 5.39	5.5	5.555 5.61	V V
$V_i$	Operating Input Voltage	$I_o = 250\text{ mA}$			20	V
$I_{out}$	Output Current Limit			300		mA
$\Delta V_o$	Line Regulation	$V_i = 6.3\text{ to }20\text{ V}$ , $I_o = 0.5\text{ mA}$		3.5	17.5	mV
$\Delta V_o(*)$	Load Regulation	$V_i = 6.5\text{ V}$ $I_o = 0.5\text{ to }250\text{ mA}$		3	15	mV
$I_d$	Quiescent Current	ON MODE $V_i = 6.5\text{ to }20\text{ V}$ $I_o = 0\text{ mA}$ $V_i = 6.5\text{ to }20\text{ V}$ $I_o = 250\text{ mA}$		0.6 4	1 6	mA mA
		OFF MODE $V_i = 6\text{ V}$		50	100	$\mu\text{A}$
SVR	Supply Voltage Rejection	$I_o = 5\text{ mA}$ $V_i = 7.5\text{ V} \pm 1\text{ V}$ $f = 120\text{ Hz}$ $f = 1\text{ KHz}$ $f = 10\text{ KHz}$		70 67 55		dB dB dB
eN	Output Noise Voltage	$B = 10\text{ Hz to }100\text{ KHz}$		50		$\mu\text{V}$
$V_d(*)$	Dropout Voltage	$I_o = 250\text{ mA}$		0.4	0.6	V
		$I_o = 250\text{ mA}$ $-40 < T_j < 125\text{ }^\circ\text{C}$			0.8	V
$V_{il}$	Control Input Logic Low	$-40 < T_a < 125\text{ }^\circ\text{C}$			0.8	V
$V_{ih}$	Control Input Logic High	$-40 < T_a < 125\text{ }^\circ\text{C}$	2			V
$I_i$	Control Input Current	$V_i = 6\text{ V}$ , $V_c = 6\text{ V}$		10		$\mu\text{A}$
$C_o$	Output Bypass Capacitance	$\text{ESR} = 0.1\text{ to }10\text{ }\Omega$ $I_o = 0\text{ to }250\text{ mA}$	2	10		$\mu\text{F}$

**ELECTRICAL CHARACTERISTICS FOR L4931Cxx55** (refer to the test circuits,  $T_j = 25\text{ }^\circ\text{C}$ ,  $C_i = 0.1\text{ }\mu\text{F}$ ,  $C_o = 2.2\text{ }\mu\text{F}$  unless otherwise specified)

Symbol	Parameter	Test Conditions	Min.	Typ.	Max.	Unit
$V_o$	Output Voltage	$I_o = 5\text{ mA}$ , $V_i = 7.5\text{ V}$ $I_o = 5\text{ mA}$ , $V_i = 7.5\text{ V}$ $-25 < T_a < 85\text{ }^\circ\text{C}$	5.39 5.28	5.5	5.61 5.72	V V
$V_i$	Operating Input Voltage	$I_o = 250\text{ mA}$			20	V
$I_{out}$	Output Current Limit			300		mA
$\Delta V_o$	Line Regulation	$V_i = 6.3\text{ to }20\text{ V}$ , $I_o = 0.5\text{ mA}$		3.5	21	mV
$\Delta V_o(*)$	Load Regulation	$V_i = 6.5\text{ V}$ $I_o = 0.5\text{ to }250\text{ mA}$		3	18	mV
$I_d$	Quiescent Current	ON MODE $V_i = 6.5\text{ to }20\text{ V}$ $I_o = 0\text{ mA}$ $V_i = 6.5\text{ to }20\text{ V}$ $I_o = 250\text{ mA}$		0.6 4	1 6	mA mA
		OFF MODE $V_i = 6\text{ V}$		50	100	$\mu\text{A}$
SVR	Supply Voltage Rejection	$I_o = 5\text{ mA}$ $V_i = 7.5\text{ V} \pm 1\text{ V}$ $f = 120\text{ Hz}$ $f = 1\text{ KHz}$ $f = 10\text{ KHz}$		70 67 55		dB dB dB
eN	Output Noise Voltage	$B = 10\text{ Hz to }100\text{ KHz}$		50		$\mu\text{V}$
$V_d(*)$	Dropout Voltage	$I_o = 250\text{ mA}$		0.4	0.6	V
		$I_o = 250\text{ mA}$ $-40 < T_j < 125\text{ }^\circ\text{C}$			0.8	V
$V_{il}$	Control Input Logic Low	$-40 < T_a < 125\text{ }^\circ\text{C}$			0.8	V
$V_{ih}$	Control Input Logic High	$-40 < T_a < 125\text{ }^\circ\text{C}$	2			V
$I_i$	Control Input Current	$V_i = 6\text{ V}$ , $V_c = 6\text{ V}$		10		$\mu\text{A}$
$C_o$	Output Bypass Capacitance	$\text{ESR} = 0.1\text{ to }10\text{ }\Omega$ $I_o = 0\text{ to }250\text{ mA}$	2	10		$\mu\text{F}$

(\*) For SO-8 package the maximum limit of load regulation and dropout is increased by 20mV



**ELECTRICAL CHARACTERISTICS FOR L4931ABxx60** (refer to the test circuits,  $T_j = 25\text{ }^\circ\text{C}$ ,  $C_i = 0.1\text{ }\mu\text{F}$ ,  $C_o = 2.2\text{ }\mu\text{F}$  unless otherwise specified)

Symbol	Parameter	Test Conditions	Min.	Typ.	Max.	Unit
$V_o$	Output Voltage	$I_o = 5\text{ mA}$ , $V_i = 8\text{ V}$	5.94	6	6.06	V
		$I_o = 5\text{ mA}$ , $V_i = 8\text{ V}$ $-25 < T_a < 85\text{ }^\circ\text{C}$	5.88		6.12	V
$V_i$	Operating Input Voltage	$I_o = 250\text{ mA}$			20	V
$I_{out}$	Output Current Limit			300		mA
$\Delta V_o$	Line Regulation	$V_i = 6.8\text{ to }20\text{ V}$ , $I_o = 0.5\text{ mA}$		4	20	mV
$\Delta V_o(*)$	Load Regulation	$V_i = 7\text{ V}$ $I_o = 0.5\text{ to }250\text{ mA}$		3	15	mV
$I_d$	Quiescent Current	ON MODE				
		$V_i = 7\text{ to }20\text{ V}$ $I_o = 0\text{ mA}$		0.8	1.6	mA
		$V_i = 7\text{ to }20\text{ V}$ $I_o = 250\text{ mA}$		4.5	7	mA
	OFF MODE $V_i = 6\text{ V}$		70	140	$\mu\text{A}$	
SVR	Supply Voltage Rejection	$I_o = 5\text{ mA}$ $V_i = 8\text{ V} \pm 1\text{ V}$				
		$f = 120\text{ Hz}$		69		dB
		$f = 1\text{ KHz}$		66		dB
		$f = 10\text{ KHz}$		55		dB
eN	Output Noise Voltage	$B = 10\text{ Hz to }100\text{ KHz}$		50		$\mu\text{V}$
$V_d(*)$	Dropout Voltage	$I_o = 250\text{ mA}$		0.4	0.6	V
		$I_o = 250\text{ mA}$ $-40 < T_j < 125\text{ }^\circ\text{C}$			0.8	V
$V_{il}$	Control Input Logic Low	$-40 < T_a < 125\text{ }^\circ\text{C}$			0.8	V
$V_{ih}$	Control Input Logic High	$-40 < T_a < 125\text{ }^\circ\text{C}$	2			V
$I_i$	Control Input Current	$V_i = 6\text{ V}$ , $V_c = 6\text{ V}$		10		$\mu\text{A}$
$C_o$	Output Bypass Capacitance	$\text{ESR} = 0.1\text{ to }10\text{ }\Omega$ $I_o = 0\text{ to }250\text{ mA}$	2	10		$\mu\text{F}$

**ELECTRICAL CHARACTERISTICS FOR L4931Cxx60** (refer to the test circuits,  $T_j = 25\text{ }^\circ\text{C}$ ,  $C_i = 0.1\text{ }\mu\text{F}$ ,  $C_o = 2.2\text{ }\mu\text{F}$  unless otherwise specified)

Symbol	Parameter	Test Conditions	Min.	Typ.	Max.	Unit
$V_o$	Output Voltage	$I_o = 5\text{ mA}$ , $V_i = 8\text{ V}$	5.88	6	6.12	V
		$I_o = 5\text{ mA}$ , $V_i = 8\text{ V}$ $-25 < T_a < 85\text{ }^\circ\text{C}$	5.76		6.24	V
$V_i$	Operating Input Voltage	$I_o = 250\text{ mA}$			20	V
$I_{out}$	Output Current Limit			300		mA
$\Delta V_o$	Line Regulation	$V_i = 6.8\text{ to }20\text{ V}$ , $I_o = 0.5\text{ mA}$		4	24	mV
$\Delta V_o(*)$	Load Regulation	$V_i = 7\text{ V}$ $I_o = 0.5\text{ to }250\text{ mA}$		3	18	mV
$I_d$	Quiescent Current	ON MODE				
		$V_i = 7\text{ to }20\text{ V}$ $I_o = 0\text{ mA}$		0.8	1.6	mA
		$V_i = 7\text{ to }20\text{ V}$ $I_o = 250\text{ mA}$		4.5	7	mA
	OFF MODE $V_i = 6\text{ V}$		70	140	$\mu\text{A}$	
SVR	Supply Voltage Rejection	$I_o = 5\text{ mA}$ $V_i = 8\text{ V} \pm 1\text{ V}$				
		$f = 120\text{ Hz}$		69		dB
		$f = 1\text{ KHz}$		66		dB
		$f = 10\text{ KHz}$		55		dB
eN	Output Noise Voltage	$B = 10\text{ Hz to }100\text{ KHz}$		50		$\mu\text{V}$
$V_d(*)$	Dropout Voltage	$I_o = 250\text{ mA}$		0.4	0.6	V
		$I_o = 250\text{ mA}$ $-40 < T_j < 125\text{ }^\circ\text{C}$			0.8	V
$V_{il}$	Control Input Logic Low	$-40 < T_a < 125\text{ }^\circ\text{C}$			0.8	V
$V_{ih}$	Control Input Logic High	$-40 < T_a < 125\text{ }^\circ\text{C}$	2			V
$I_i$	Control Input Current	$V_i = 6\text{ V}$ , $V_c = 6\text{ V}$		10		$\mu\text{A}$
$C_o$	Output Bypass Capacitance	$\text{ESR} = 0.1\text{ to }10\text{ }\Omega$ $I_o = 0\text{ to }250\text{ mA}$	2	10		$\mu\text{F}$

(\*) For SO-8 package the maximum limit of load regulation and dropout is increased by 20mV

## L4931 SERIES

**ELECTRICAL CHARACTERISTICS FOR L4931ABxx80** (refer to the test circuits,  $T_j = 25\text{ }^\circ\text{C}$ ,  $C_i = 0.1\text{ }\mu\text{F}$ ,  $C_o = 2.2\text{ }\mu\text{F}$  unless otherwise specified)

Symbol	Parameter	Test Conditions	Min.	Typ.	Max.	Unit
$V_o$	Output Voltage	$I_o = 5\text{ mA}$ , $V_i = 10\text{ V}$	7.92	8	8.08	V
		$I_o = 5\text{ mA}$ , $V_i = 10\text{ V}$ $-25 < T_a < 85\text{ }^\circ\text{C}$	7.84		8.16	V
$V_i$	Operating Input Voltage	$I_o = 250\text{ mA}$			20	V
$I_{out}$	Output Current Limit			300		mA
$\Delta V_o$	Line Regulation	$V_i = 8.8\text{ to }20\text{ V}$ , $I_o = 0.5\text{ mA}$		4	20	mV
$\Delta V_o(*)$	Load Regulation	$V_i = 9\text{ V}$ $I_o = 0.5\text{ to }250\text{ mA}$		3	15	mV
$I_d$	Quiescent Current	ON MODE				
		$V_i = 9\text{ to }20\text{ V}$ $I_o = 0\text{ mA}$		0.8	1.6	mA
		$V_i = 9\text{ to }20\text{ V}$ $I_o = 250\text{ mA}$		4.5	7	mA
		OFF MODE $V_i = 6\text{ V}$		70	140	$\mu\text{A}$
SVR	Supply Voltage Rejection	$I_o = 5\text{ mA}$ $V_i = 10\text{ V} \pm 1\text{ V}$				
		$f = 120\text{ Hz}$		67		dB
		$f = 1\text{ KHz}$		64		dB
		$f = 10\text{ KHz}$		55		dB
eN	Output Noise Voltage	$B = 10\text{ Hz to }100\text{ KHz}$		50		$\mu\text{V}$
$V_d(*)$	Dropout Voltage	$I_o = 250\text{ mA}$		0.4	0.6	V
		$I_o = 250\text{ mA}$ $-40 < T_j < 125\text{ }^\circ\text{C}$			0.8	V
$V_{il}$	Control Input Logic Low	$-40 < T_a < 125\text{ }^\circ\text{C}$			0.8	V
$V_{ih}$	Control Input Logic High	$-40 < T_a < 125\text{ }^\circ\text{C}$	2			V
$I_i$	Control Input Current	$V_i = 6\text{ V}$ , $V_c = 6\text{ V}$		10		$\mu\text{A}$
$C_o$	Output Bypass Capacitance	$\text{ESR} = 0.1\text{ to }10\text{ }\Omega$ $I_o = 0\text{ to }250\text{ mA}$	2	10		$\mu\text{F}$

**ELECTRICAL CHARACTERISTICS FOR L4931Cxx80** (refer to the test circuits,  $T_j = 25\text{ }^\circ\text{C}$ ,  $C_i = 0.1\text{ }\mu\text{F}$ ,  $C_o = 2.2\text{ }\mu\text{F}$  unless otherwise specified)

Symbol	Parameter	Test Conditions	Min.	Typ.	Max.	Unit
$V_o$	Output Voltage	$I_o = 5\text{ mA}$ , $V_i = 10\text{ V}$	7.84	8	8.16	V
		$I_o = 5\text{ mA}$ , $V_i = 10\text{ V}$ $-25 < T_a < 85\text{ }^\circ\text{C}$	7.68		8.32	V
$V_i$	Operating Input Voltage	$I_o = 250\text{ mA}$			20	V
$I_{out}$	Output Current Limit			300		mA
$\Delta V_o$	Line Regulation	$V_i = 8.9\text{ to }20\text{ V}$ , $I_o = 0.5\text{ mA}$		4	24	mV
$\Delta V_o(*)$	Load Regulation	$V_i = 9.1\text{ V}$ $I_o = 0.5\text{ to }250\text{ mA}$		3	18	mV
$I_d$	Quiescent Current	ON MODE				
		$V_i = 9.1\text{ to }20\text{ V}$ $I_o = 0\text{ mA}$		0.8	1.6	mA
		$V_i = 9.1\text{ to }20\text{ V}$ $I_o = 250\text{ mA}$		4.5	7	mA
		OFF MODE $V_i = 6\text{ V}$		70	140	$\mu\text{A}$
SVR	Supply Voltage Rejection	$I_o = 5\text{ mA}$ $V_i = 10.1\text{ V} \pm 1\text{ V}$				
		$f = 120\text{ Hz}$		67		dB
		$f = 1\text{ KHz}$		64		dB
		$f = 10\text{ KHz}$		55		dB
eN	Output Noise Voltage	$B = 10\text{ Hz to }100\text{ KHz}$		50		$\mu\text{V}$
$V_d(*)$	Dropout Voltage	$I_o = 250\text{ mA}$		0.4	0.6	V
		$I_o = 250\text{ mA}$ $-40 < T_j < 125\text{ }^\circ\text{C}$			0.8	V
$V_{il}$	Control Input Logic Low	$-40 < T_a < 125\text{ }^\circ\text{C}$			0.8	V
$V_{ih}$	Control Input Logic High	$-40 < T_a < 125\text{ }^\circ\text{C}$	2			V
$I_i$	Control Input Current	$V_i = 6\text{ V}$ , $V_c = 6\text{ V}$		10		$\mu\text{A}$
$C_o$	Output Bypass Capacitance	$\text{ESR} = 0.1\text{ to }10\text{ }\Omega$ $I_o = 0\text{ to }250\text{ mA}$	2	10		$\mu\text{F}$

(\*) For SO-8 package the maximum limit of load regulation and dropout is increased by 20mV

**ELECTRICAL CHARACTERISTICS FOR L4931ABxx120** (refer to the test circuits,  $T_j = 25\text{ }^\circ\text{C}$ ,  $C_i = 0.1\text{ }\mu\text{F}$ ,  $C_o = 2.2\text{ }\mu\text{F}$  unless otherwise specified)

Symbol	Parameter	Test Conditions	Min.	Typ.	Max.	Unit
$V_o$	Output Voltage	$I_o = 5\text{ mA}$ , $V_i = 14\text{ V}$ $I_o = 5\text{ mA}$ , $V_i = 14\text{ V}$ $-25 < T_a < 85\text{ }^\circ\text{C}$	11.88 11.76	12	12.12 12.24	V V
$V_i$	Operating Input Voltage	$I_o = 250\text{ mA}$			20	V
$I_{out}$	Output Current Limit			300		mA
$\Delta V_o$	Line Regulation	$V_i = 12.8\text{ to }20\text{ V}$ , $I_o = 0.5\text{ mA}$		4	20	mV
$\Delta V_o(*)$	Load Regulation	$V_i = 13\text{ V}$ $I_o = 0.5\text{ to }250\text{ mA}$		3	15	mV
$I_d$	Quiescent Current	ON MODE $V_i = 13\text{ to }20\text{ V}$ $I_o = 0\text{ mA}$ $V_i = 13\text{ to }20\text{ V}$ $I_o = 250\text{ mA}$		0.8 4.5	1.6 7	mA mA
		OFF MODE $V_i = 6\text{ V}$		90	180	$\mu\text{A}$
SVR	Supply Voltage Rejection	$I_o = 5\text{ mA}$ $V_i = 14\text{ V} \pm 1\text{ V}$ $f = 120\text{ Hz}$ $f = 1\text{ KHz}$ $f = 10\text{ KHz}$		64 61 55		dB dB dB
eN	Output Noise Voltage	$B = 10\text{ Hz to }100\text{ KHz}$		50		$\mu\text{V}$
$V_d(*)$	Dropout Voltage	$I_o = 250\text{ mA}$		0.4	0.6	V
		$I_o = 250\text{ mA}$ $-40 < T_j < 125\text{ }^\circ\text{C}$			0.8	V
$V_{il}$	Control Input Logic Low	$-40 < T_a < 125\text{ }^\circ\text{C}$			0.8	V
$V_{ih}$	Control Input Logic High	$-40 < T_a < 125\text{ }^\circ\text{C}$	2			V
$I_i$	Control Input Current	$V_i = 6\text{ V}$ , $V_c = 6\text{ V}$		10		$\mu\text{A}$
$C_o$	Output Bypass Capacitance	$\text{ESR} = 0.1\text{ to }10\text{ }\Omega$ $I_o = 0\text{ to }250\text{ mA}$	2	10		$\mu\text{F}$

**ELECTRICAL CHARACTERISTICS FOR L4931Cxx120** (refer to the test circuits,  $T_j = 25\text{ }^\circ\text{C}$ ,  $C_i = 0.1\text{ }\mu\text{F}$ ,  $C_o = 2.2\text{ }\mu\text{F}$  unless otherwise specified)

Symbol	Parameter	Test Conditions	Min.	Typ.	Max.	Unit
$V_o$	Output Voltage	$I_o = 5\text{ mA}$ , $V_i = 14\text{ V}$ $I_o = 5\text{ mA}$ , $V_i = 14\text{ V}$ $-25 < T_a < 85\text{ }^\circ\text{C}$	11.76 11.52	12	12.24 12.48	V V
$V_i$	Operating Input Voltage	$I_o = 250\text{ mA}$			20	V
$I_{out}$	Output Current Limit			300		mA
$\Delta V_o$	Line Regulation	$V_i = 12.9\text{ to }20\text{ V}$ , $I_o = 0.5\text{ mA}$		4	24	mV
$\Delta V_o(*)$	Load Regulation	$V_i = 13.1\text{ V}$ $I_o = 0.5\text{ to }250\text{ mA}$		3	18	mV
$I_d$	Quiescent Current	ON MODE $V_i = 13.1\text{ to }20\text{ V}$ $I_o = 0\text{ mA}$ $V_i = 13.1\text{ to }20\text{ V}$ $I_o = 250\text{ mA}$		0.8 4.5	1.6 7	mA mA
		OFF MODE $V_i = 6\text{ V}$		90	180	$\mu\text{A}$
SVR	Supply Voltage Rejection	$I_o = 5\text{ mA}$ $V_i = 14.1\text{ V} \pm 1\text{ V}$ $f = 120\text{ Hz}$ $f = 1\text{ KHz}$ $f = 10\text{ KHz}$		64 61 55		dB dB dB
eN	Output Noise Voltage	$B = 10\text{ Hz to }100\text{ KHz}$		50		$\mu\text{V}$
$V_d(*)$	Dropout Voltage	$I_o = 250\text{ mA}$		0.4	0.6	V
		$I_o = 250\text{ mA}$ $-40 < T_j < 125\text{ }^\circ\text{C}$			0.8	V
$V_{il}$	Control Input Logic Low	$-40 < T_a < 125\text{ }^\circ\text{C}$			0.8	V
$V_{ih}$	Control Input Logic High	$-40 < T_a < 125\text{ }^\circ\text{C}$	2			V
$I_i$	Control Input Current	$V_i = 6\text{ V}$ , $V_c = 6\text{ V}$		10		$\mu\text{A}$
$C_o$	Output Bypass Capacitance	$\text{ESR} = 0.1\text{ to }10\text{ }\Omega$ $I_o = 0\text{ to }250\text{ mA}$	2	10		$\mu\text{F}$

(\*) For SO-8 package the maximum limit of load regulation and dropout is increased by 20mV

# L4931 SERIES

## TYPICAL PERFORMANCE CHARACTERISTICS (unless otherwise specified $T_j = 25\text{ }^\circ\text{C}$ )

Supply Current vs Output Current

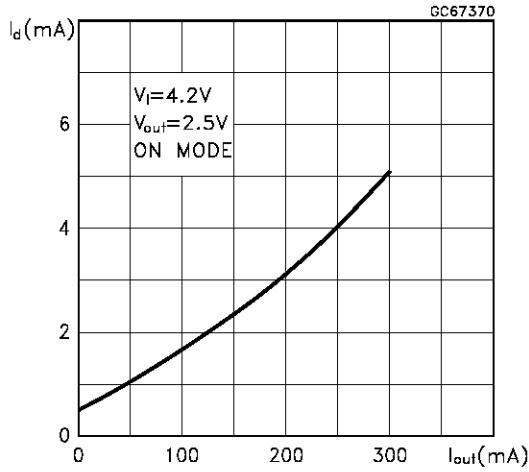

Dropout Voltage vs Temperature

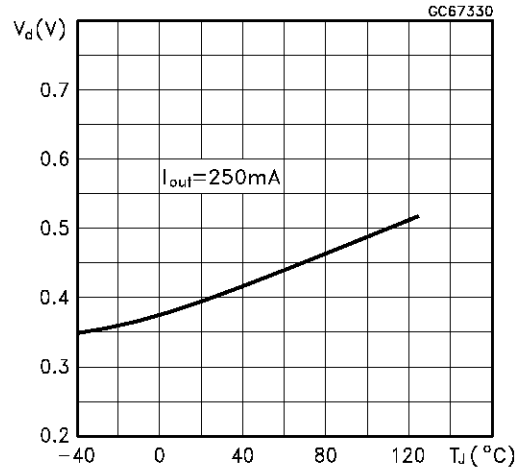

Supply Current vs Input Voltage

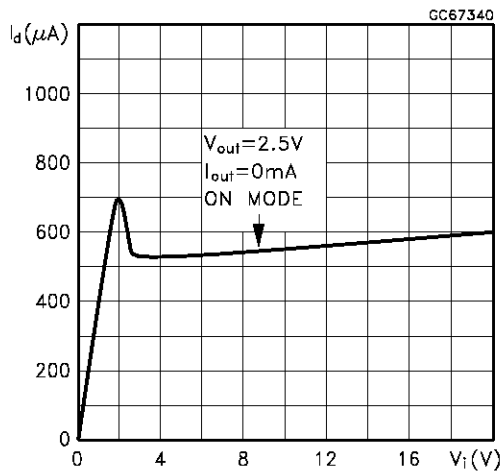

Supply Current vs Temperature

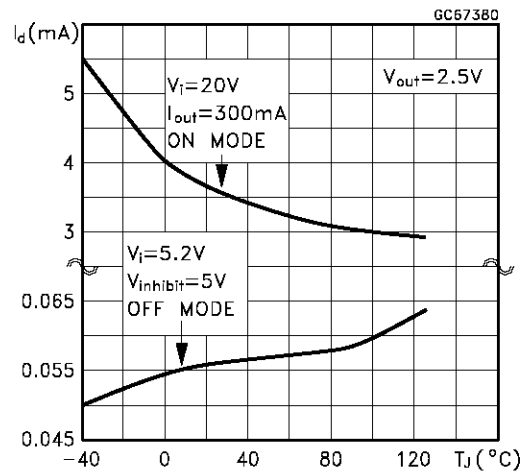

Short Circuit Current vs Dropout Voltage

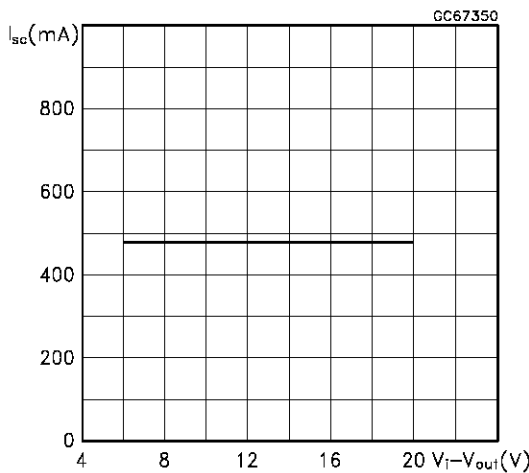

S.V.R. vs Input Voltage Signal Frequency

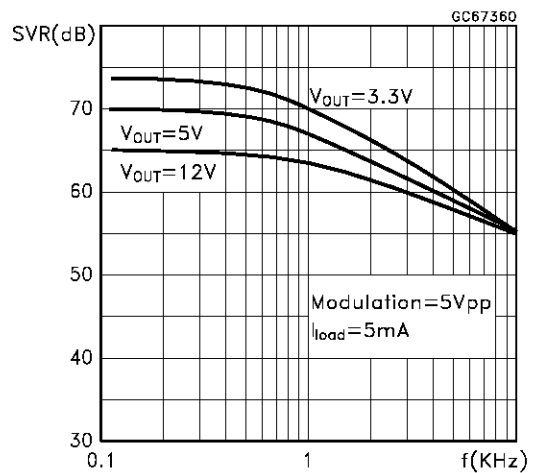

## TO-220 MECHANICAL DATA

DIM.	mm			inch		
	MIN.	TYP.	MAX.	MIN.	TYP.	MAX.
A			4.8			0.189
C			1.37			0.054
D	2.4		2.8	0.094		0.110
D1	1.2		1.35	0.047		0.053
E	0.35		0.55	0.014		0.022
F	0.8		1.05	0.031		0.041
F2	1.15		1.4	0.045		0.055
G	4.95	5.08	5.21	0.195	0.200	0.205
H2			10.4			0.409
H3	10.05		10.4	0.396		0.409
L2		16.2			0.638	
L3	26.3	26.7	27.1	1.035	1.051	1.067
L5	2.6		3	0.102		0.118
L6	15.1		15.8	0.594		0.622
L7	6		6.6	0.236		0.260
Dia.	3.65		3.85	0.144		0.152

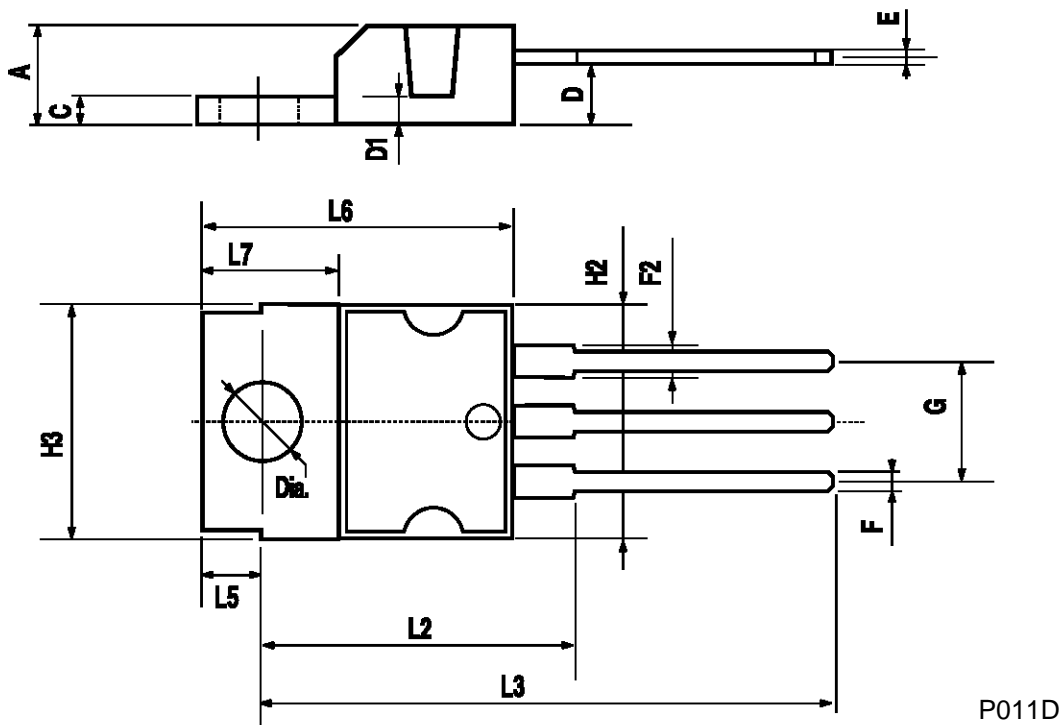

**SO8 MECHANICAL DATA**

DIM.	mm			inch		
	MIN.	TYP.	MAX.	MIN.	TYP.	MAX.
A			1.75			0.068
a1	0.1		0.25	0.003		0.009
a2			1.65			0.064
a3	0.65		0.85	0.025		0.033
b	0.35		0.48	0.013		0.018
b1	0.19		0.25	0.007		0.010
C	0.25		0.5	0.010		0.019
c1	45° (typ.)					
D	4.8		5.0	0.188		0.196
E	5.8		6.2	0.228		0.244
e		1.27			0.050	
e3		3.81			0.150	
F	3.8		4.0	0.14		0.157
L	0.4		1.27	0.015		0.050
M			0.6			0.023
S	8° (max.)					

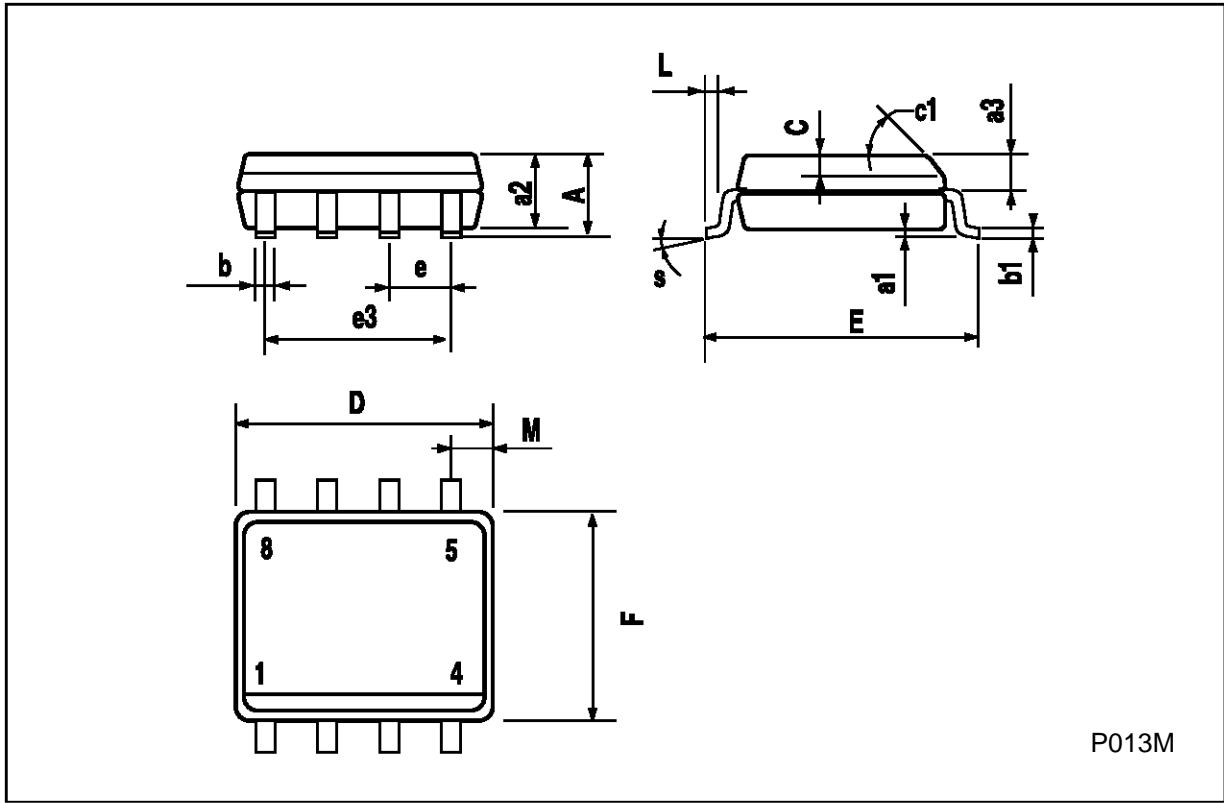

**PPAK MECHANICAL DATA**

DIM.	mm			inch		
	MIN.	TYP.	MAX.	MIN.	TYP.	MAX.
A	2.2		2.4	0.086		0.094
A1	0.9		1.1	0.035		0.043
A2	0.03		0.23	0.001		0.009
B		0.5			0.019	
B2	5.2		5.4	0.204		0.212
C	0.45		0.53	0.017		0.021
C2		0.5			0.019	
D	6		6.2	0.236		0.244
E	6.4		6.6	0.252		0.260
G		5.08			0.200	
G1		2.54			0.100	
H	9.35		10.1	0.368		0.397
L2		0.8			0.031	
L4	0.6		1	0.023		0.039

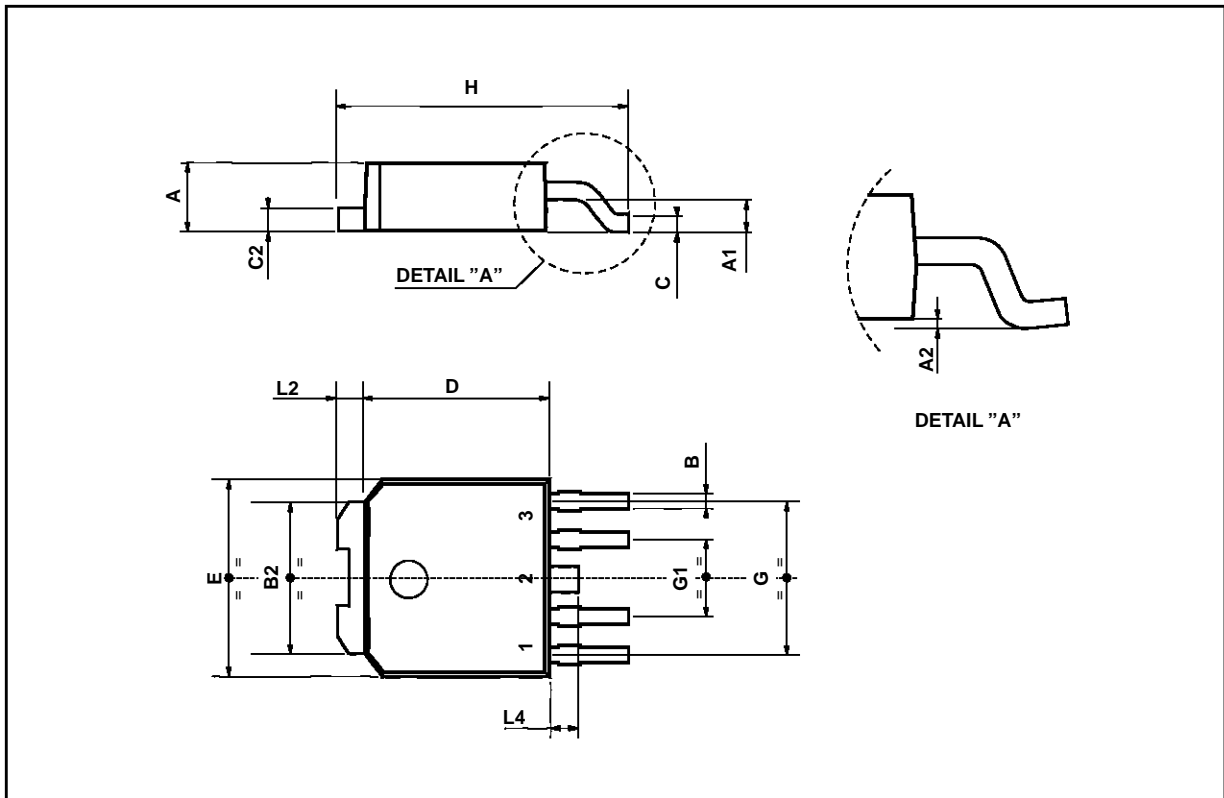

TO-252 (DPAK) MECHANICAL DATA

DIM.	mm			inch		
	MIN.	TYP.	MAX.	MIN.	TYP.	MAX.
A	2.2		2.4	0.086		0.094
A1	0.9		1.1	0.035		0.043
A2	0.03		0.23	0.001		0.009
B	0.64		0.9	0.025		0.035
B2	5.2		5.4	0.204		0.212
C	0.45		0.6	0.017		0.023
C2	0.48		0.6	0.019		0.023
D	6		6.2	0.236		0.244
E	6.4		6.6	0.252		0.260
G	4.4		4.6	0.173		0.181
H	9.35		10.1	0.368		0.397
L2		0.8			0.031	
L4	0.6		1	0.023		0.039

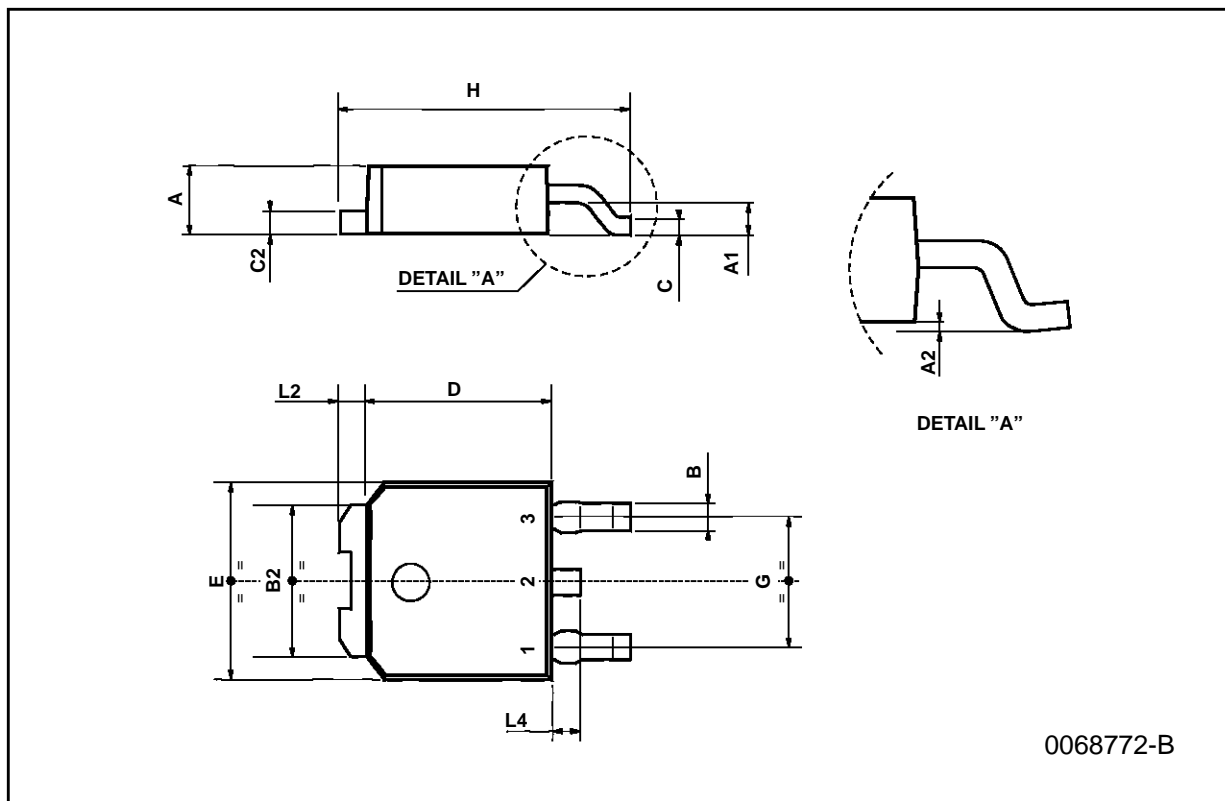



Information furnished is believed to be accurate and reliable. However, SGS-THOMSON Microelectronics assumes no responsibility for the consequences of use of such information nor for any infringement of patents or other rights of third parties which may result from its use. No license is granted by implication or otherwise under any patent or patent rights of SGS-THOMSON Microelectronics. Specifications mentioned in this publication are subject to change without notice. This publication supersedes and replaces all information previously supplied. SGS-THOMSON Microelectronics products are not authorized for use as critical components in life support devices or systems without express written approval of SGS-THOMSON Microelectronics.

© 1995 SGS-THOMSON Microelectronics - Printed in Italy - All Rights Reserved

SGS-THOMSON Microelectronics GROUP OF COMPANIES

Australia - Brazil - Canada - China - France - Germany - Hong Kong - Italy - Japan - Korea - Malaysia - Malta - Morocco - The Netherlands - Singapore - Spain - Sweden - Switzerland - Taiwan - Thailand - United Kingdom - U.S.A